

Service  
Service  
Service



# Service Manual



Contents	Page	Contents	Page
1 Technical Specifications and Connection Facilities	2	8 Exploded View & Spare Parts List	31
2 Measurements Setup, Service Aid & Lead Free Requirements	4	Exploded View of the set	31
3 Dismantling Instructions & Service Positions	8	Spare Part List	32
4 Service Test Program	10	Revision List	36
5 FTD Display Pin Connection	12		
6 Block Diagram	13		
Wiring Diagram	14		
7 Circuit Diagram and PWB Layout	15		
Front: Display	15		
Front: Display (Top view)	16		
Front: Display (Bottom view)	17		
Front: Standby	18		
Mono Board: Circuit Diagram (Part 1)	19		
Mono Board: Circuit Diagram (Part 2)	20		
Mono Board: Circuit Diagram (Part 3)	21		
Mono Board: Circuit Diagram (Part 4)	22		
Mono Board: Circuit Diagram (Part 5)	23		
Mono Board: Circuit Diagram (Part 6)	24		
Mono Board: Circuit Diagram (Part 7)	25		
Mono Board: Circuit Diagram (Part 8)	26		
Mono Board: Circuit Diagram (Part 9)	27		
Layout: Mono Board (Top View)	28		
Layout: Mono Board (Bottom View)	29		
PSU Circuit Diagram	30		

©Copyright 2005 Philips Consumer Electronics B.V. Eindhoven, The Netherlands.  
 All rights reserved. No part of this publication may be reproduced, stored in a retrieval system or transmitted, in any form or by any means, electronic, mechanical, photocopying, or otherwise without the prior permission of Philips.





# 1. Specifications

## 1.1 General:

Mains voltage	: 230V for /05, /12, /51 120V/230V for /55 /93 /98
Mains frequency	: 50/60Hz for /98, /55, /93, 50Hz for /12, /05, /51
Power consumption	: 70W < 0.5W Eco standby power < 70W at 1/8 P <sub>rated</sub> (For main unit)
Dimension main unit	: 360 x 54 x 324mm

## 1.2 Tuner FM

Tuning range	: 87.5-108MHz
Grid	: 50kHz for /12, /05, /51 100kHz for /98, /55, /93
IF frequency	: 10.7MHz ± 25kHz
Aerial input	: 75Ω coaxial
Sensitivity at 26dB S/N	: < 7μV
Selectivity at 600kHz bandwidth	: > 25dB
IF rejection	: > 60dB
Image rejection	: > 25dB
Distortion at RF=1mV, dev. 75kHz	: < 3%
-3dB Limiting point	: 8μV
Crosstalk at RF=1mV, dev. 67.5kHz	: > 28dB
Crosstalk at RF=1mV, dev. 40kHz	: > 18dB

## MW

Tuning range	: 531-1602kHz for /12, /05, /51, /98, /93, /55 530-1700kHz for /98, /55, /93
Grid	: 9kHz for /12, /05, /51, /98, /93, /55 10kHz for /98, /55, /93
IF frequency	: 450kHz ± 1kHz
Aerial input	: Frame aerial
Sensitivity at 26dB S/N	: < 4.0mV/M
Selectivity at 18kHz bandwidth	: > 20dB
IF rejection	: > 45dB
Image rejection	: > 28dB
Distortion at RF=50mV, m=80%	: < 5%

## 1.3 AMPLIFIER:

Output power	
Front	: 100W RMS / channel
Rear	: 75W RMS / channel
Center	: 100W RMS
Subwoofer	: 150W RMS
Frequency response ±0.5dB	: 20Hz-20kHz
Hum (Volume Minimum)	: 200nW
Residual noise (Volume Minimum)	: 40nW
Input sensitivity	
Aux In	: 1V ± 3dB at 22kΩ
Scart In	: 1V ± 3dB at 22kΩ
Output sensitivity	
Line Out (Left/Right)	: 1V ± 2dB at 10kΩ
Scart Out (Left/Right)	: 1V ± 2dB at 10kΩ

## 1.4 COMPACT DISC/VCD/DVD:

Video Decoding	: MPEG-1/MPEG-2/ MPEG-4/DivX 3.11, 4.x & 5.x
Video DAC	: 12 Bits
Signal System	: PAL / NTSC
Video Format	: 4:3 / 16:9
CVBS Out <sup>1)</sup>	
CVBS level	: 1.0 ± 0.1V <sub>p-p</sub>
Luminance S/N	: ≥ 60dB
S-Video Out <sup>1)</sup>	
Y level	: 1.0 ± 0.1V <sub>p-p</sub>
Y S/N	: ≥ 60dB
C level (burst)	: 286mV <sub>pp</sub> +1/-4 dB
RGB/YUV Out <sup>1)</sup>	
Amplitude	: 0.7 ± 0.1V <sub>p-p</sub>
S/N	: ≥ 60dB

<sup>1)</sup> Output terminals to be terminated with 75Ω

## 2. Measurements Setup, Service Aid & Lead Free Requirements

### MEASUREMENT SETUP

#### Tuner FM

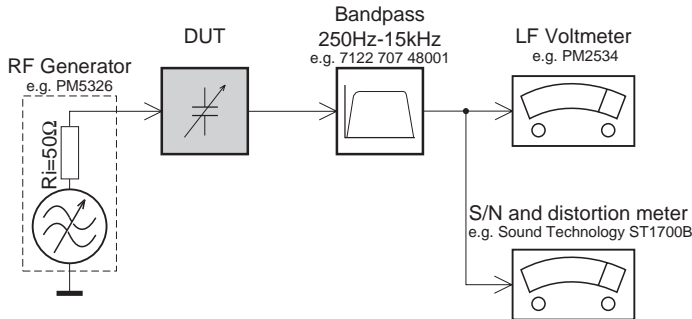

Use a bandpass filter to eliminate hum (50Hz, 100Hz) and disturbance from the pilotone (19kHz, 38kHz).

#### Tuner AM (MW,LW)

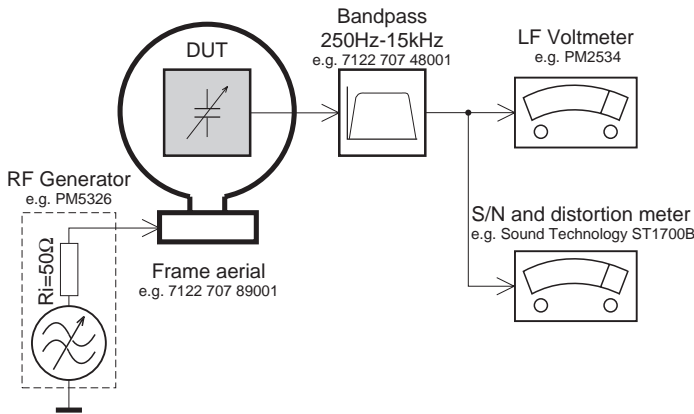

To avoid atmospheric interference all AM-measurements have to be carried out in a Faraday's cage. Use a bandpass filter (or at least a high pass filter with 250Hz) to eliminate hum (50Hz, 100Hz).

#### CD

Use Audio Signal Disc SBC429 4822 397 30184 (replaces test disc 3)

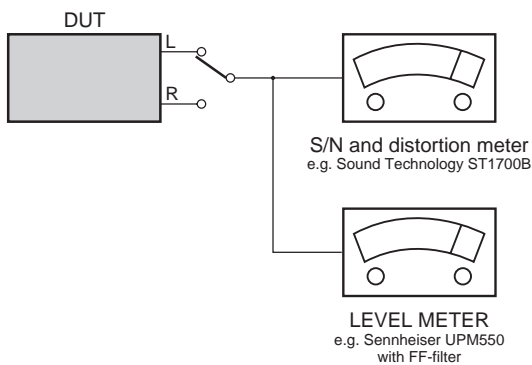

#### Recorder

Use Universal Test Cassette **CrO2** SBC419 4822 397 30069 or Universal Test Cassette **Fe** SBC420 4822 397 30071

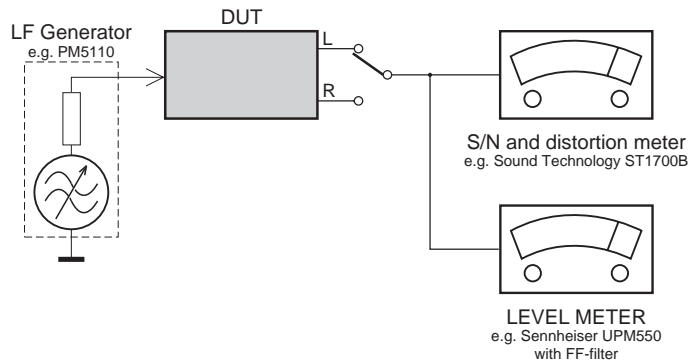

## SERVICE AIDS

### Service Tools:

Universal Torx driver holder .....	4822 395 91019
Torx bit T10 150mm .....	4822 395 50456
Torx driver set T6 - T20 .....	4822 395 50145
Torx driver T10 extended .....	4822 395 50423

### Compact Disc:

SBC426/426A Test disc 5 + 5A .....	4822 397 30096
SBC442 Audio Burn-in Test disc 1kHz .....	4822 397 30155
SBC429 Audio Signals disc .....	4822 397 30184
Dolby Pro-logic Test Disc .....	4822 395 10216

## HANDLING CHIP COMPONENTS

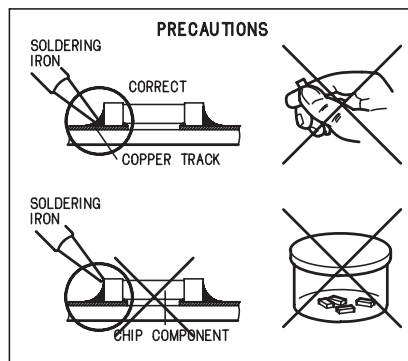
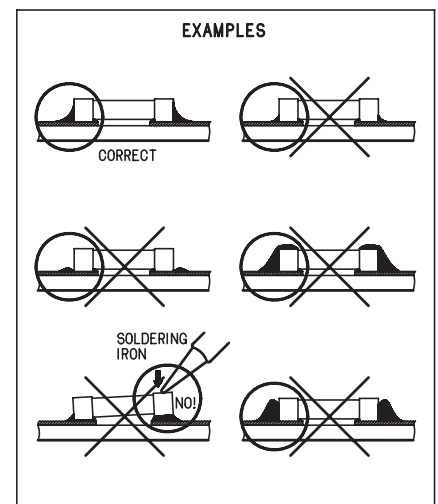
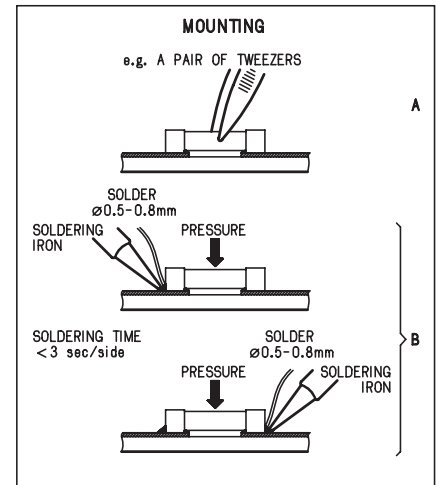
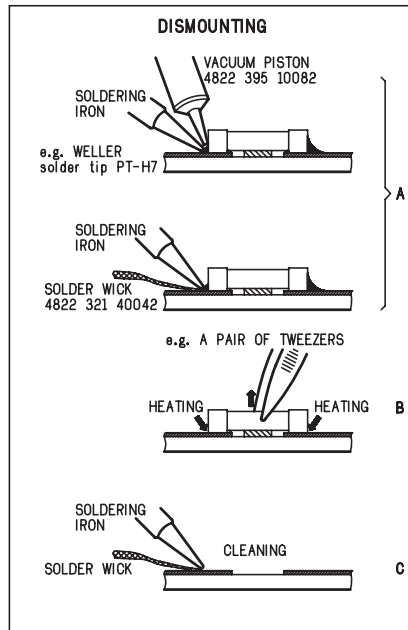
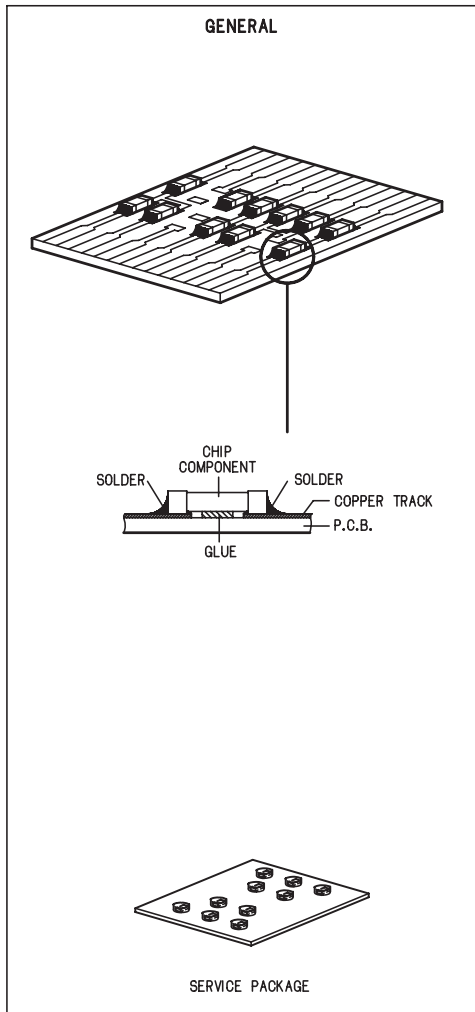

**(GB) WARNING**

All ICs and many other semi-conductors are susceptible to electrostatic discharges (ESD). Careless handling during repair can reduce life drastically.

When repairing, make sure that you are connected with the same potential as the mass of the set via a wrist wrap with resistance. Keep components and tools also at this potential.

**ESD****(NL) WAARSCHUWING**

Alle IC's en vele andere halfgeleiders zijn gevoelig voor electrostatische ontladingen (ESD). Onzorgvuldig behandelen tijdens reparatie kan de levensduur drastisch doen verminderen. Zorg ervoor dat u tijdens reparatie via een polsband met weerstand verbonden bent met hetzelfde potentiaal als de massa van het apparaat.

Houd componenten en hulpmiddelen ook op hetzelfde potentiaal.

**(F) ATTENTION**

Tous les IC et beaucoup d'autres semi-conducteurs sont sensibles aux décharges statiques (ESD).

Leur longévité pourrait être considérablement écourtée par le fait qu'aucune précaution n'est prise à leur manipulation.

Lors de réparations, s'assurer de bien être relié au même potentiel que la masse de l'appareil et enfiler le bracelet serti d'une résistance de sécurité.

Veiller à ce que les composants ainsi que les outils que l'on utilise soient également à ce potentiel.

**(D) WARNUNG**

Alle ICs und viele andere Halbleiter sind empfindlich gegenüber elektrostatischen Entladungen (ESD).

Unvorsichtige Behandlung im Reparaturfall kann die Lebensdauer drastisch reduzieren.

Veranlassen Sie, dass Sie im Reparaturfall über ein Pulsarmband mit Widerstand verbunden sind mit dem gleichen Potential wie die Masse des Gerätes.

Bauteile und Hilfsmittel auch auf dieses gleiche Potential halten.

**(I) AVVERTIMENTO**

Tutti IC e parecchi semi-conduttori sono sensibili alle scariche statiche (ESD).

La loro longevità potrebbe essere fortemente ridotta in caso di non osservazione della più grande cauzione alla loro manipolazione.

Durante le riparazioni occorre quindi essere collegato allo stesso potenziale che quello della massa dell'apparecchio tramite un braccialetto a resistenza.

Assicurarsi che i componenti e anche gli utensili con quali si lavora siano anche a questo potenziale.

**(GB) ESD PROTECTION EQUIPMENT:**

Complete Kit ESD3 (small tablemat, wristband, connection box, extension cable and earth cable) ..... 4822 310 10671  
Wristband tester ..... 4822 344 13999

**(GB)**

Safety regulations require that the set be restored to its original condition and that parts which are identical with those specified, be used

Safety components are marked by the symbol  $\triangle$ .

**(NL)**

Veiligheidsbepalingen vereisen, dat het apparaat bij reparatie in zijn oorspronkelijke toestand wordt teruggebracht en dat onderdelen, identiek aan de gespecificeerde, worden toegepast.

De Veiligheidsonderdelen zijn aangeduid met het symbool  $\triangle$ .

**(F)**

Les normes de sécurité exigent que l'appareil soit remis à l'état d'origine et que soient utilisées les pièces de rechange identiques à celles spécifiées.

Less composants de sécurité sont marqués  $\triangle$ .

**(D)**

Bei jeder Reparatur sind die geltenden Sicherheitsvorschriften zu beachten. Der Originalzustand des Geräts darf nicht verändert werden; für Reparaturen sind Original-Ersatzteile zu verwenden.

Sicherheitsbauteile sind durch das Symbol  $\triangle$  markiert.

**(I)**

Le norme di sicurezza esigono che l'apparecchio venga rimesso nelle condizioni originali e che siano utilizzati i pezzi di ricambio identici a quelli specificati.

Componenti di sicurezza sono marcati con  $\triangle$ .

**(GB)**

After servicing and before returning set to customer perform a leakage current measurement test from all exposed metal parts to earth ground to assure no shock hazard exist. The leakage current must not exceed 0.5mA.

**(GB) Warning !**

Invisible laser radiation when open.  
Avoid direct exposure to beam.

**(S) Varning !**

Osynlig laserstrålning när apparaten är öppnad och spårren är urkopplad. Betrakta ej strålen.

**(SF) Varoitus !**

Avatussa laitteessa ja suojalukituksen ohitettaessa olet alltiina näkymättömälle laserisäteilylle. Älä katso säteeseen!

**(DK) Advarse !**

Usynlig laserstrålning ved åbning når sikkerhedsafbrydere er ude af funktion. Undgå udsættelse for strålning.

**(F)**

"Pour votre sécurité, ces documents doivent être utilisés par des spécialistes agréés, seuls habilités à réparer votre appareil en panne".

## 2.1 Lead Free Requirements

### Pb(Lead) Free Solder

When soldering, be sure to use the pb free solder.

#### IDENTIFICATION:



Regardless of special logo (not always indicated)

one must treat all sets from **1 Jan 2005** onwards, according next rules:

Important note: In fact also products of year 2004 must be treated in this way as long as you avoid mixing solder-alloys (lead/ lead-free). So best to always use SAC305 and the higher temperatures belong to this.

Due to lead-free technology some rules have to be respected by the workshop during a repair:

- Use only lead-free solder alloy Philips SAC305 with order code 0622 149 00106. If lead-free solder-paste is required, please contact the manufacturer of your solder-equipment. In general use of solder-paste within workshops should be avoided because paste is not easy to store and to handle.
  - Use only adequate solder tools applicable for lead-free solder alloy. The solder tool must be able
    - o To reach at least a solder-temperature of 400°C,
    - o To stabilize the adjusted temperature at the solder-tip
    - o To exchange solder-tips for different applications.
  - Adjust your solder tool so that a temperature around 360°C – 380°C is reached and stabilized at the solder joint. Heating-time of the solder-joint should not exceed ~ 4 sec. Avoid temperatures above 400°C otherwise wear-out of tips will rise drastically and flux-fluid will be destroyed. To avoid wear-out of tips switch off un-used equipment, or reduce heat.
  - Mix of lead-free solder alloy / parts with leaded solder alloy / parts is possible but PHILIPS recommends strongly to avoid mixed solder alloy types (leaded and lead-free).  
If one cannot avoid or does not know whether product is lead-free, clean carefully the solder-joint from old solder alloy and re-solder with new solder alloy (SAC305).
  - Use only original spare-parts listed in the Service-Manuals. Not listed standard-material (commodities) has to be purchased at external companies.
  - Special information for BGA-ICs:
    - always use the 12nc-recognizable soldering temperature profile of the specific BGA (for de-soldering always use the lead-free temperature profile, in case of doubt)
    - lead free BGA-ICs will be delivered in so-called 'dry-packaging' (sealed pack including a silica gel pack) to protect the IC against moisture. After opening, dependent of MSL-level seen on indicator-label in the bag, the BGA-IC possibly still has to be baked dry. (MSL=Moisture Sensitivity Level). This will be communicated via AYS-website.
- Do not re-use BGAs at all.

- For sets produced before 1.1.2005 (except products of 2004), containing leaded solder-alloy and components, all needed spare-parts will be available till the end of the service-period. For repair of such sets nothing changes.

- On our website [www.atyourservice.ce.Philips.com](http://www.atyourservice.ce.Philips.com) you find more information to:

- BGA-de-/soldering (+ baking instructions)
- Heating-profiles of BGAs and other ICs used in Philips-sets

You will find this and more technical information within the "magazine", chapter "workshop news".

For additional questions please contact your local repair-helpdesk.

## 3. Dismantling Instructions

### 3.1 Dismantling of the DVD Loader

- 1) The tray can be manually open by inserting a minus screw drive and push the lever in the direction as shown in Figure 3-1 to unlock the tray before sliding it out.



Figure 3-1

- 2) Slide out the tray and remove the Cover Tray (pos 110) as shown in Figure 3-2.

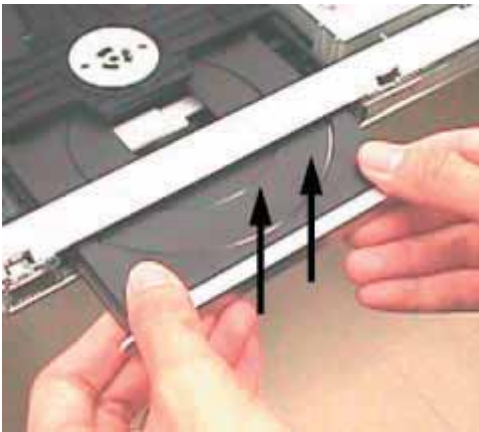

Figure 3-2

- 3) Loosen 5 screws to remove the Front Top.(pos 240)
  - 1 screw each on the left & right side (pos 272)
  - 3 screws behind
- 4) Loosen 4 screws C (see Figure 3-4) to remove the DVD Loader.

### 3.2 Dismantling of the Tuner Module, MONO Board, Front Board, PSU Module

- 1) Loosen 1 screw A (see Figure 3-3) to remove the Tuner Module (pos 1040).
- 2) Loosen 9 screws B (see Figure 3-3) and 4 screws (see Figure 3-4) to remove MONO Board.
- 3) Release 4 snap hooks to remove Front Board.
  - 1 snap hook each on the left & right side (pos 161).
  - 2 snap hooks on the bottom side (pos 161).
- 4) Loosen 4 screws E (see Figure 3-4) to remove the PSU Module.

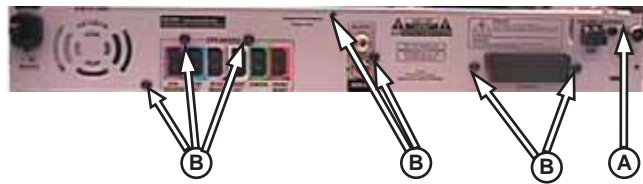

Figure 3-3

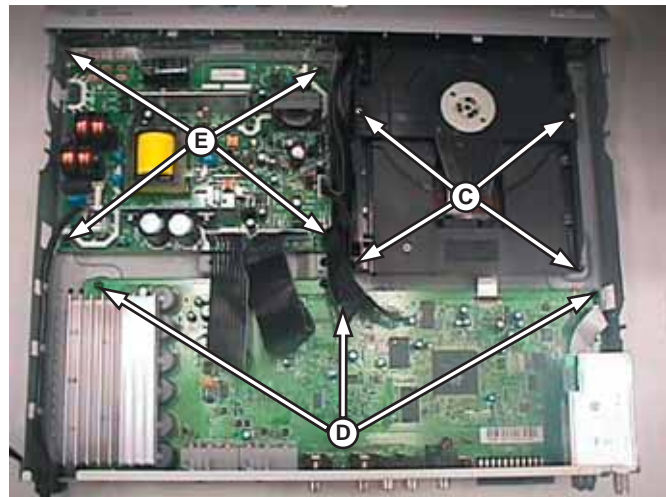
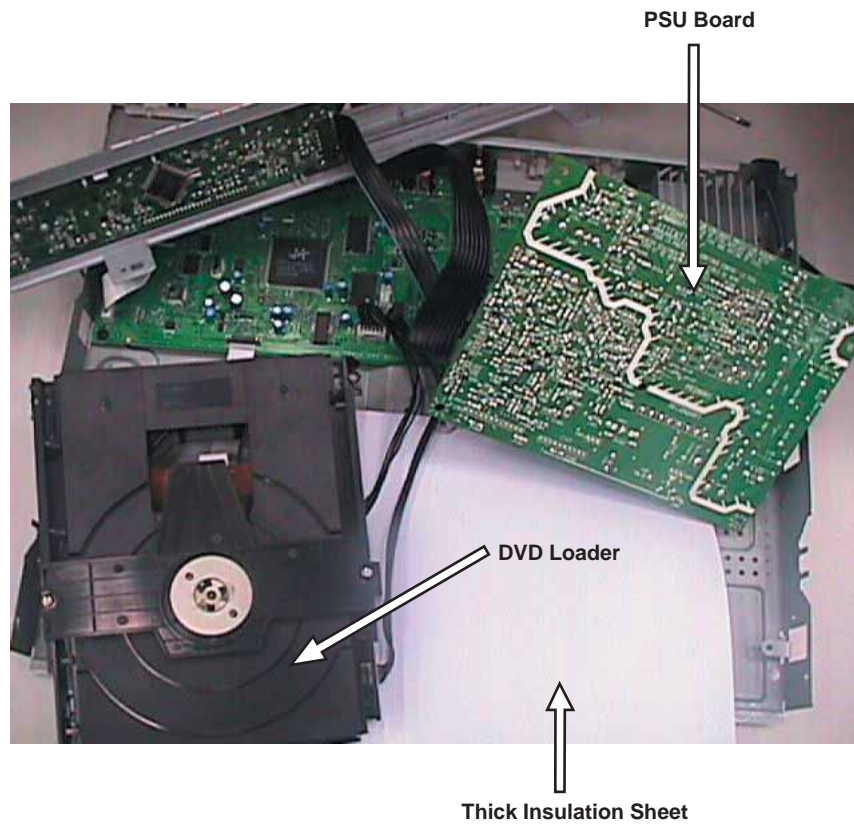
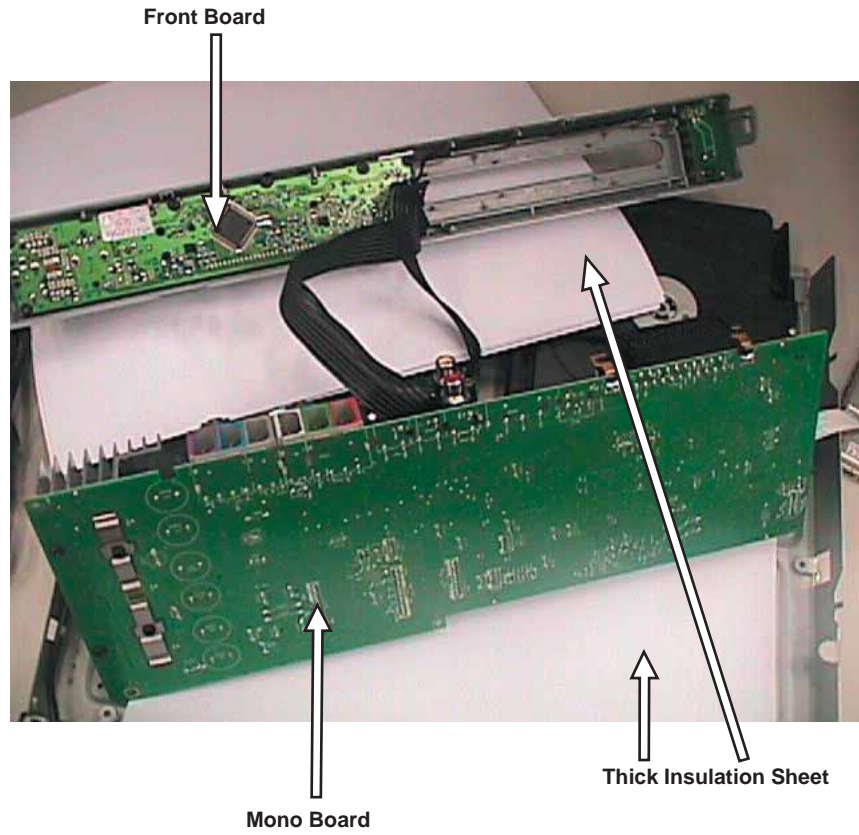

Figure 3-4



### 3.3 Service Positions



# 4. Service Test Program

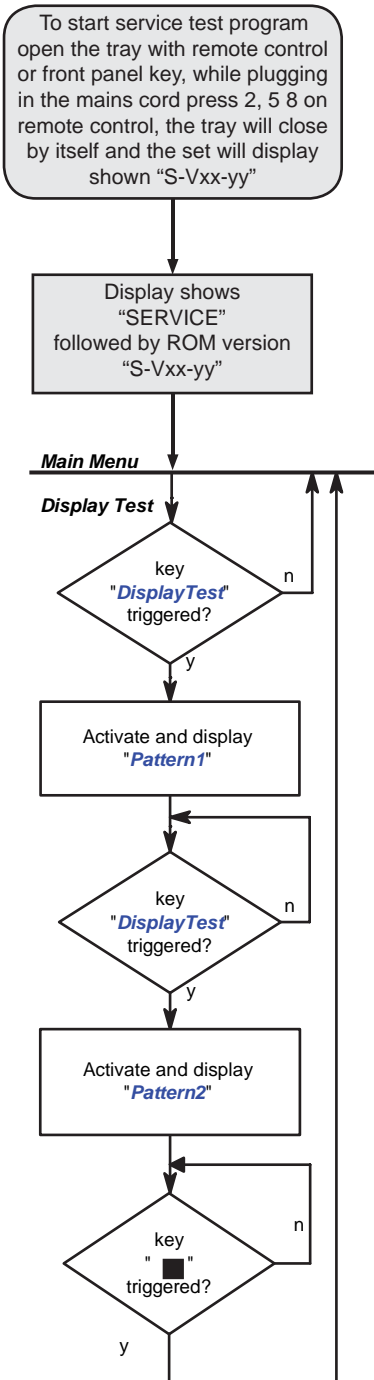

S refers to Service Mode  
 V refers to Version  
 xx refers to Software version number of BEA (counting up from 01 to 99)  
 yy refers to Software version number of Front uP (counting up from 01 to 99)

## 4.1 Display Test

**Purpose:**  
 This test is used to check the driving circuits, the display and whether there are any short-circuits, open-circuits or any other defects.

**Player:**  
 Following display patterns are used to test the display and its connections to μP.  
 Pattern 1: *Default: All display control pins are ON*  
 - to check the open-circuits



Pattern 2: *Alternate display control pins are on (Test Pattern: 0x55)*  
 - to check the short-circuits on Data port





**Receiver:**  
 Following display patterns are used to test the display and its connections to μP.  
 Pattern 1: *Default: All display control pins are ON*  
 - to check the open-circuits



Pattern 2: *Alternate display control pins are on (Test Pattern: 0x55)*  
 - to check the short-circuits on Data port



TEST	Activated with	ACTION
EEPROM FORMAT TEST	  to Exit	Load default data. Display shows "NEW". Caution! All presets from the customer will be lost!!
ROTARY ENCODER TEST	Volume Knob	Display shows value for 2 seconds. Volume values increases or decreases in steps of 1 until 0 (VOL MIN) or 40 (VOL MAX) is reached.
LEAVE SERVICE TEST PROGRAM	Disconnect mains cord	

#### 4.1.1 Reprogramming of DVD version Matrix

After repair, the customer setting and region code may be lost. Reprogramming will put the set back in the state in which it has left the factory, ie. with the default setting and the allowed region code.

Model	Region	Region Code	TV Type
HTS 3300/05	UK, Ireland	2	PAL
HTS 3300/12	Europe	2	PAL
HTS 3300/51	Russia	5	PAL
HTS 3300/55	Latam	4	NTSL
HTS 3300/93	China	6	PAL
HTS 3300/98	Asia Pacific	3	PAL

To reprogram do as follows:

- 1) Power up the set and select DISC source.
- 2) Open tray by press "OPEN/CLOSE" button on the set or press and hold "STOP" button on the RC.
- 3) Press the following buttons on the Remote Control:

<9> <9> <9> <9> <SVBT> <8> ..... for HTS 3300/12  
 <9> <9> <9> <9> <SVBT> <9> .....for HTS 3300/51  
 <9> <9> <9> <9> <AUDIO> <0> .....for HTS 3300/05  
 <9> <9> <9> <9> <AUDIO> <1> .....for HTS 3300/98  
 <9> <9> <9> <9> <AUDIO> <3> .....for HTS 3300/93  
 <9> <9> <9> <9> <AUDIO> <4> .....for HTS 3300/55

- 4) The display shows 'YYYY-ZZ' and the tray will close.  
 YYYY = model number (eg. 8300, 8500, etc.)  
 ZZ = slash stroke version (eg. 01, 69, etc.)

#### 4.1.2 Procedure for check Software version

- 1) Power up the set and select DISC source.
- 2) Open tray by press "OPEN/CLOSE" button on the set or press and hold "STOP" button on the RC.
- 3) Press "DISPLAY" button on the Remote control.
- 4) The TV screen will shows:

**SD6.3 Vxx YYYY-ZZ A BB**  
**SERVO: nnnnnnnn REG:A**

xx = version number  
 YYYY = model number (eg. 8300, 8500, etc.)  
 ZZ = slash stroke version (eg. 01, 69, etc.)  
 A = region code  
 BB = Front uP software version number  
 nnnnnnnn = servo version number

#### 4.1.3 Burning of firmware

1. Unzip the zip-archive attached with this service information.
2. Start the CD burning software and create a new CD Project (Data disc) with the following settings:
  - a. File System: ISO9660
  - b. Format: MODE 2/XA
  - c. Recording format: Single Session (Track at once), Finalized CD
3. Place the content of the zip-archive into the root directory of the new CD project.
4. Burn the data onto a blank CDR or CDRW.

Note: ISO9660 is mandatory, UDF discs are not supported!  
 The final CDROM must not contain any other data except the file from the zip-archive.

#### 4.1.4 Procedure to upgrade the firmware

1. Power up the set and open tray.
2. Insert the prepared Upgrade CDROM and close the tray.
3. The set will display:

LOAD -> MULTICH ->..... ->UPG END.  
 The whole process takes less than 2 minutes.

*Note: Do not press any button or interrupt the main supply upgrading process, Otherwise the set may become defective.*

4. When the upgrade is completed, the tray will close automatic.
5. The tray will close and the set will go to Standby mode automatically when the upgrade process is completed.

#### 4.1.5 Procedure to check the firmware version to confirm upgrading

1. Power up the set and open tray.
2. Press the <Menu Display> button on the Remote Control.
3. The firmware version will be displayed on the top left hand corner of the OSD.

#### 4.1.6 Trade Mode

Trade mode is a feature that will block all set keys when enabled. It is for dealers to prevent customers from removing disc, changing source etc using the set keys. Rotary and Remote Control (RC) keys are still allowed in Trade mode.

##### To activate Trade Mode:

- 1) Power up the set and select DISC source.
- 2) Open tray by press "OPEN/CLOSE" button on the set or press and hold "STOP" button on the RC.
- 3) Then press buttons <2> <5> <9> on the RC.
- 4) The display shows 'TRA ON' and the tray will close. Trade Mode is now enabled.

##### To deactivate Trade Mode:

- 1) Power up the set and select DISC source.
- 2) Open tray by press and hold "STOP" button on the RC.
- 3) Then press buttons <2> <5> <9> on the RC.
- 4) The display shows 'TRA OFF' and the tray will close. Trade Mode is now disabled.

#### 4.1.7 Procedure to change Tuner Grid (not for all versions)

- 1 Press **SOURCE** to select "FM" or "FM1".
- 2 Press **STANDBY ON** to switch the DVD system to standby mode.
- 3 Press **STANDBY ON** again to turn on the DVD system and hold down  button on the front panel.  
 → The display will show "GRID 9" or "GRID 10".

##### Helpful Hint:

– GRID 9 and GRID 10 indicate that the tuning grid is in step of 9 kHz and 10 kHz respectively.

*Note: Repeating the same action will toggle back to its previous tuning grid setting.*

### 5. FTD Display Pin Connection

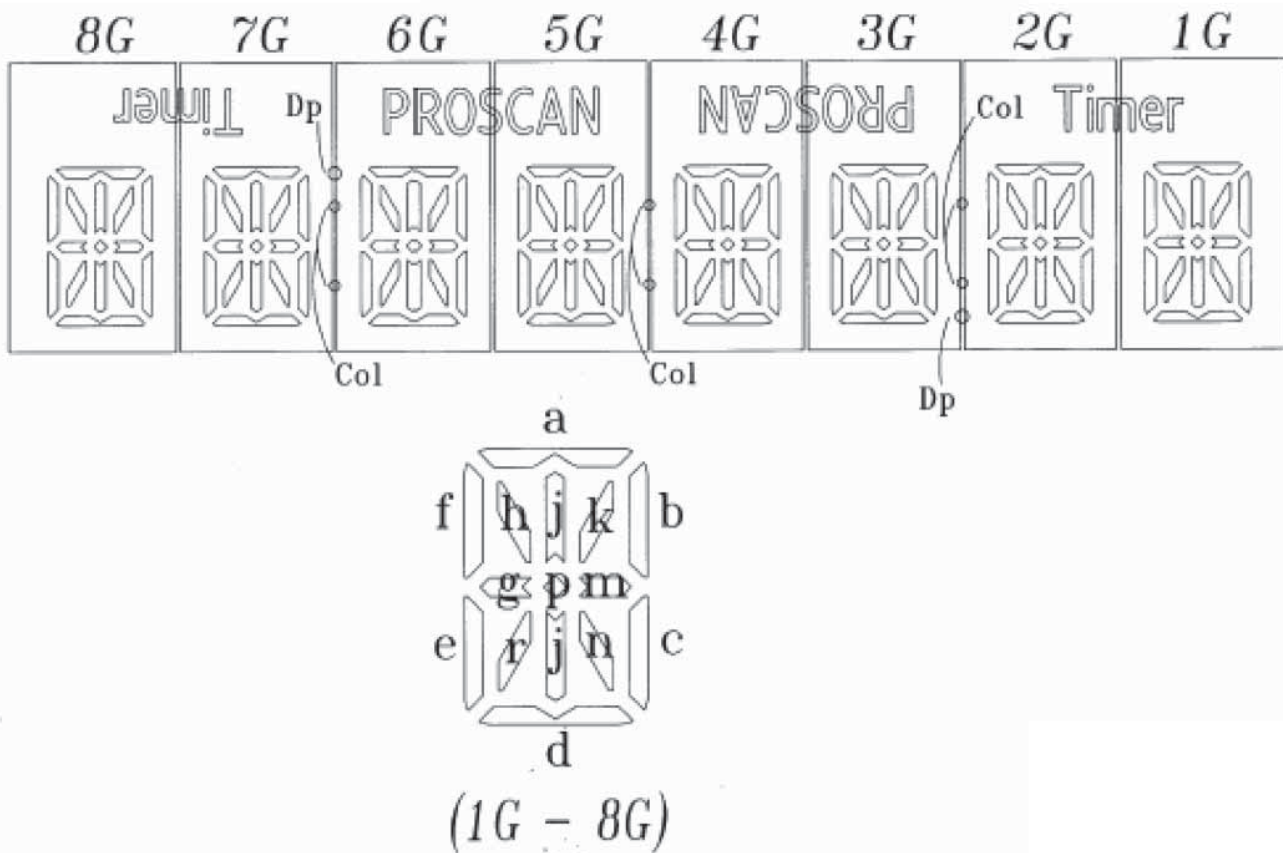

	8G	7G	6G	5G	4G	3G	2G	1G
P1	a	a	a	a	a	a	a	a
P2	j	j	j	j	j	j	j	j
P3	h	h	h	h	h	h	h	h
P4	k	k	k	k	k	k	k	k
P5	b	b	b	b	b	b	b	b
P6	f	f	f	f	f	f	f	f
P7	m	m	m	m	m	m	m	m
P8	g	g	g	g	g	g	g	g
P9	c	c	c	c	c	c	c	c
P10	e	e	e	e	e	e	e	e
P11	r	r	r	r	r	r	r	r
P12	n	n	n	n	n	n	n	n
P13	d	d	d	d	d	d	d	d
P14		col		col		col		
P15	p	p	p	p	p	p	p	p
P16	Timer		PROSCAN		PROSCAN		Timer	
P17		dp				dp		

### 6. Block Diagram

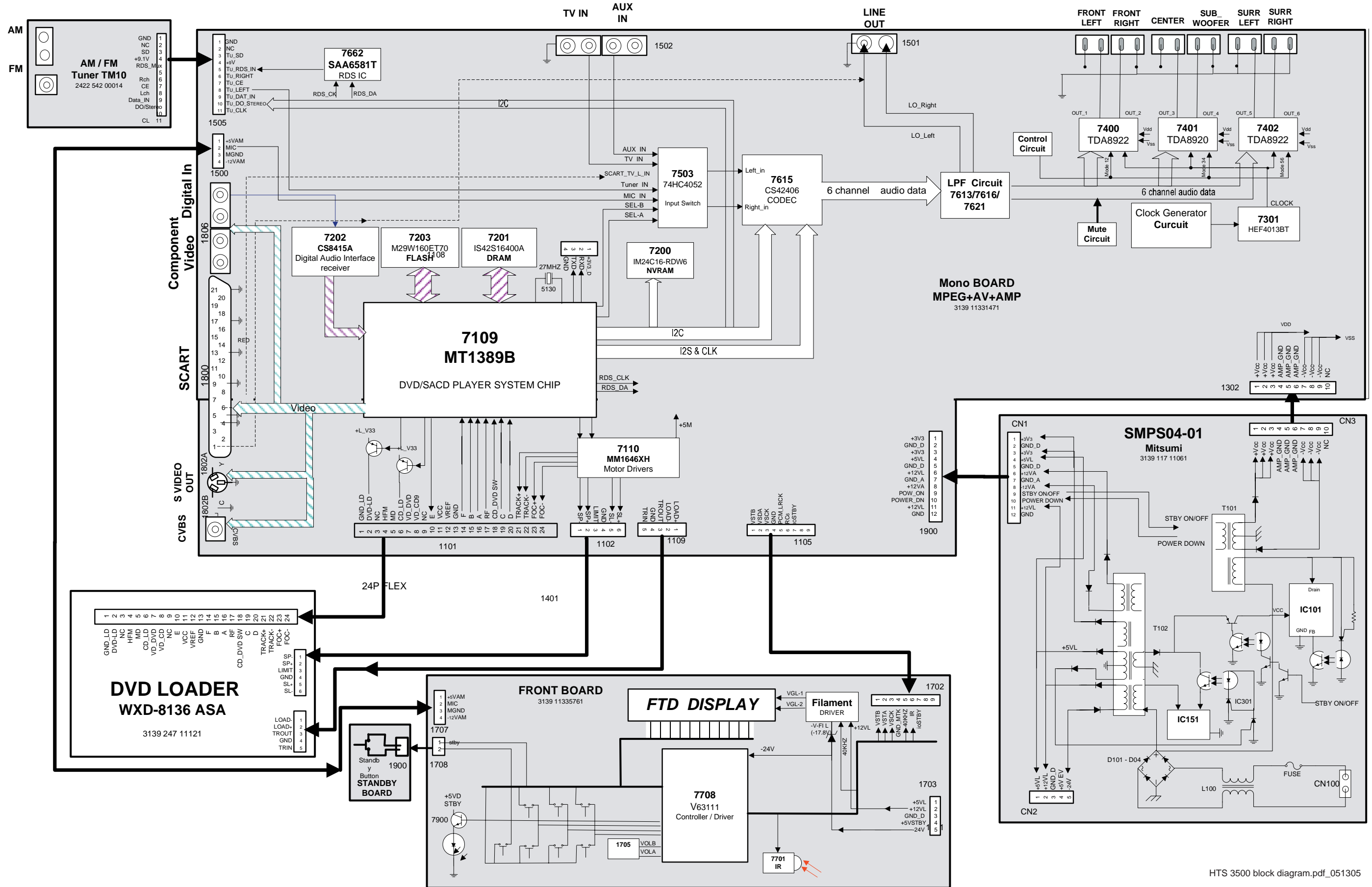

# Wiring Diagram

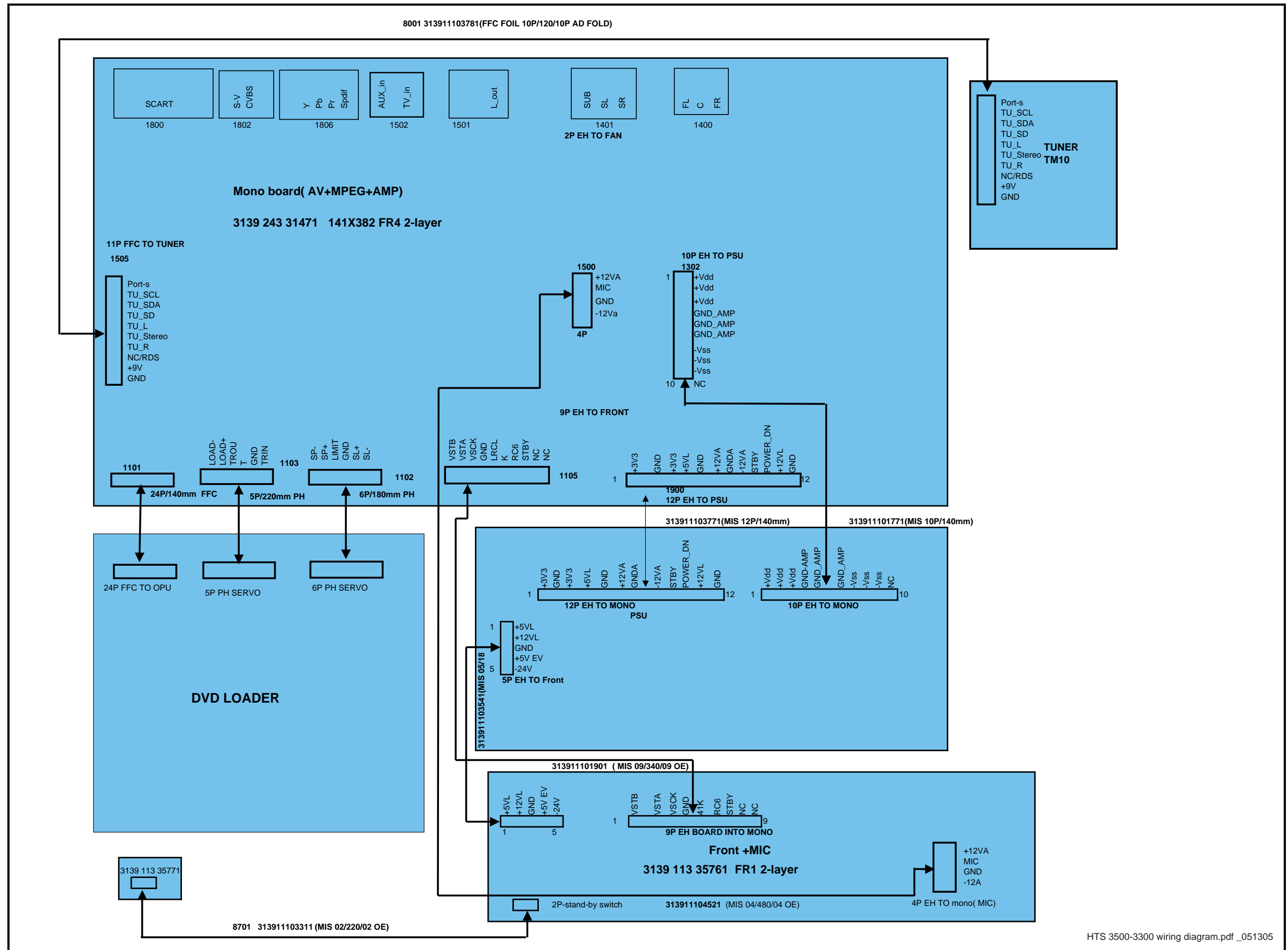

# 7. Front: Display

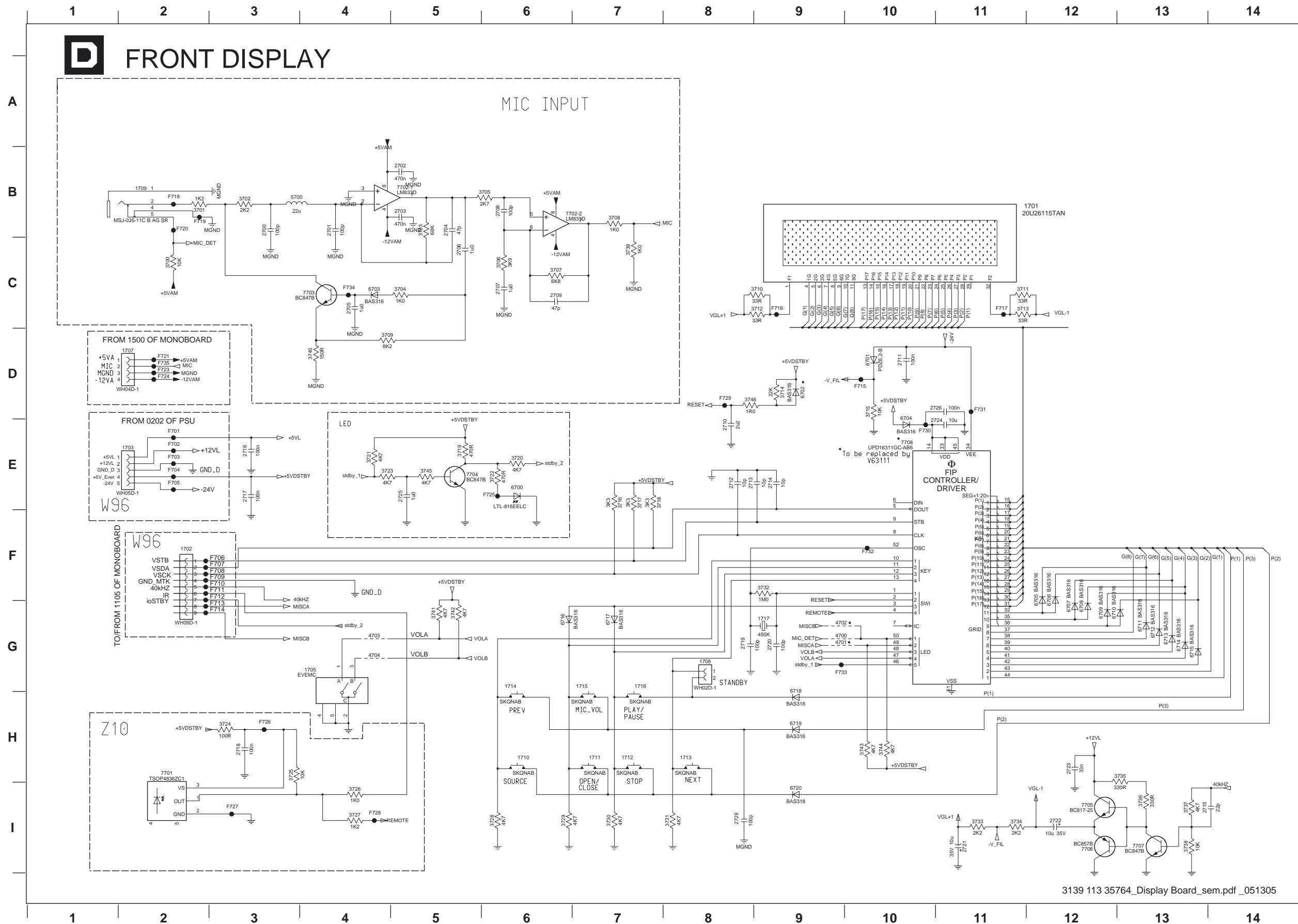

- 1701 B12
- 1702 F2
- 1703 E2
- 1705 G4
- 1707 D2
- 1708 G8
- 1709 B2
- 1710 H6
- 1711 H7
- 1712 H7
- 1713 H8
- 1714 G6
- 1715 G7
- 1716 G7
- 1717 G9
- 2700 B3
- 2701 B4
- 2702 B5
- 2703 B5
- 2704 B5
- 2705 C4
- 2706 C5
- 2707 C6
- 2708 B6
- 2709 C6
- 2710 E8
- 2711 D10
- 2712 E8
- 2713 E8
- 2714 E9
- 2715 I3
- 2716 E3
- 2717 E3
- 2718 H3
- 2719 G8
- 2720 G9
- 2721 I1
- 2722 I2
- 2723 H12
- 2724 E11
- 2725 E5
- 2726 D1
- 2727 C2
- 2728 B2
- 3702 B3
- 3703 B5
- 3704 C5
- 3705 B6
- 3706 C6
- 3707 C6
- 3708 B7
- 3709 D4
- 3710 C9
- 3711 C11
- 3712 C9
- 3713 C11
- 3714 D9
- 3715 D10
- 3716 E7
- 3717 E7
- 3718 E7
- 3719 E5
- 3720 E6
- 3721 E4
- 3722 E6
- 3723 E4
- 3724 H3
- 3725 H3
- 3726 I4
- 3727 I4
- 3728 I6
- 3729 I6
- 3730 I7
- 3731 I8
- 3732 F9
- 3733 I11
- 3734 I11
- 3735 H13
- 3736 I13
- 3737 H13
- 3738 I13
- 3739 H7
- 3740 D5
- 3741 G5
- 3742 G5
- 3743 H10
- 3744 H10
- 3745 E5
- 3746 D8
- 4700 G9
- 4701 G9
- 4702 G9
- 4703 G4
- 4704 G4
- 4705 B3
- 4706 E6
- 4707 D10
- 4708 D9
- 4709 C4
- 4710 E10
- 4711 F12
- 4712 G12
- 4713 G12
- 4714 G13
- 4715 G13
- 4716 G6
- 4717 G7
- 4718 H9
- 4719 H9
- 6720 I9
- 6701 H2
- 6702-1 B5
- 6703 C4
- 6704 E5
- 6705 I12
- 6706 I12
- 6707 I13
- 6708 E10
- 6709 E2
- 6710 E2
- 6711 E2
- 6712 E2
- 6713 E2
- 6714 E2
- 6715 E2
- 6716 D10
- 6717 F3
- 6718 F3
- 6719 F3
- 6720 F3
- 6721 F3
- 6722 G3
- 6723 G3
- 6724 G3
- 6725 G3
- 6726 D10
- 6727 E6
- 6728 H3
- 6729 I3
- 6730 I4
- 6731 D10
- 6732 F10
- 6733 G9
- 6734 C4
- 6735 D2

### Front: Display (topview)

1701 A4 1703 A1 1707 A7 1709 A7 1711 A1 1713 A4 1715 A7 1717 A6 2722 A5 7701 A2  
1702 A1 1705 A7 1708 A1 1710 A1 1712 A5 1714 A3 1716 A2 2721 A6 6700 A2

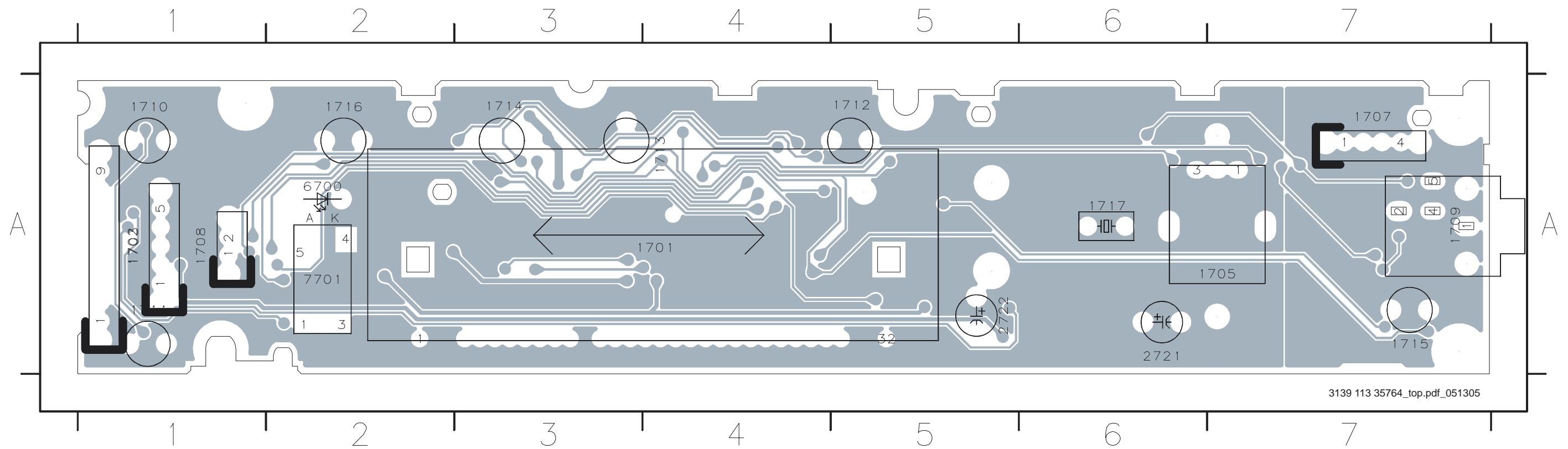



Front: Display (Bottom view)

2700 A1	2708 A1	2716 A7	2726 A3	3706 A1	3714 A6	3722 A6	3730 A3	3738 A2	3746 A5	6702 A6	6710 A5	6718 A3	7707 A2
2701 A1	2709 A1	2717 A7	2729 A1	3707 A1	3715 A3	3723 A6	3731 A5	3739 A1	4700 A4	6703 A1	6711 A5	6719 A4	7708 A4
2702 A1	2710 A4	2718 A6	3700 A1	3708 A1	3716 A6	3724 A6	3732 A2	3740 A1	4701 A4	6704 A5	6712 A5	6720 A3	
2703 A1	2711 A3	2719 A2	3701 A1	3709 A1	3717 A6	3725 A6	3733 A2	3741 A5	4702 A5	6705 A5	6713 A5	7702 A1	
2704 A1	2712 A7	2720 A2	3702 A1	3710 A6	3718 A6	3726 A6	3734 A3	3742 A5	4703 A1	6706 A5	6714 A5	7703 A1	
2705 A1	2713 A7	2723 A2	3703 A1	3711 A3	3719 A6	3727 A6	3735 A2	3743 A5	4704 A2	6707 A5	6715 A5	7704 A6	
2706 A1	2714 A7	2724 A3	3704 A1	3712 A6	3720 A6	3728 A5	3736 A2	3744 A5	5700 A1	6708 A5	6716 A3	7705 A2	
2707 A1	2715 A2	2725 A6	3705 A1	3713 A3	3721 A6	3729 A1	3737 A2	3745 A6	6701 A3	6709 A5	6717 A3	7706 A2	

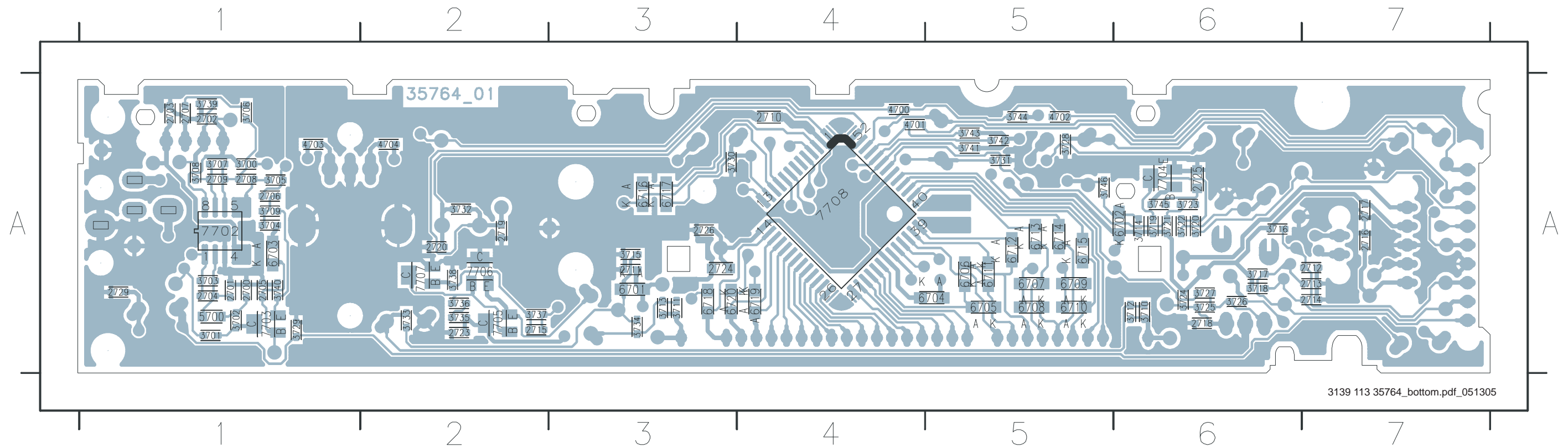

Front: Standby

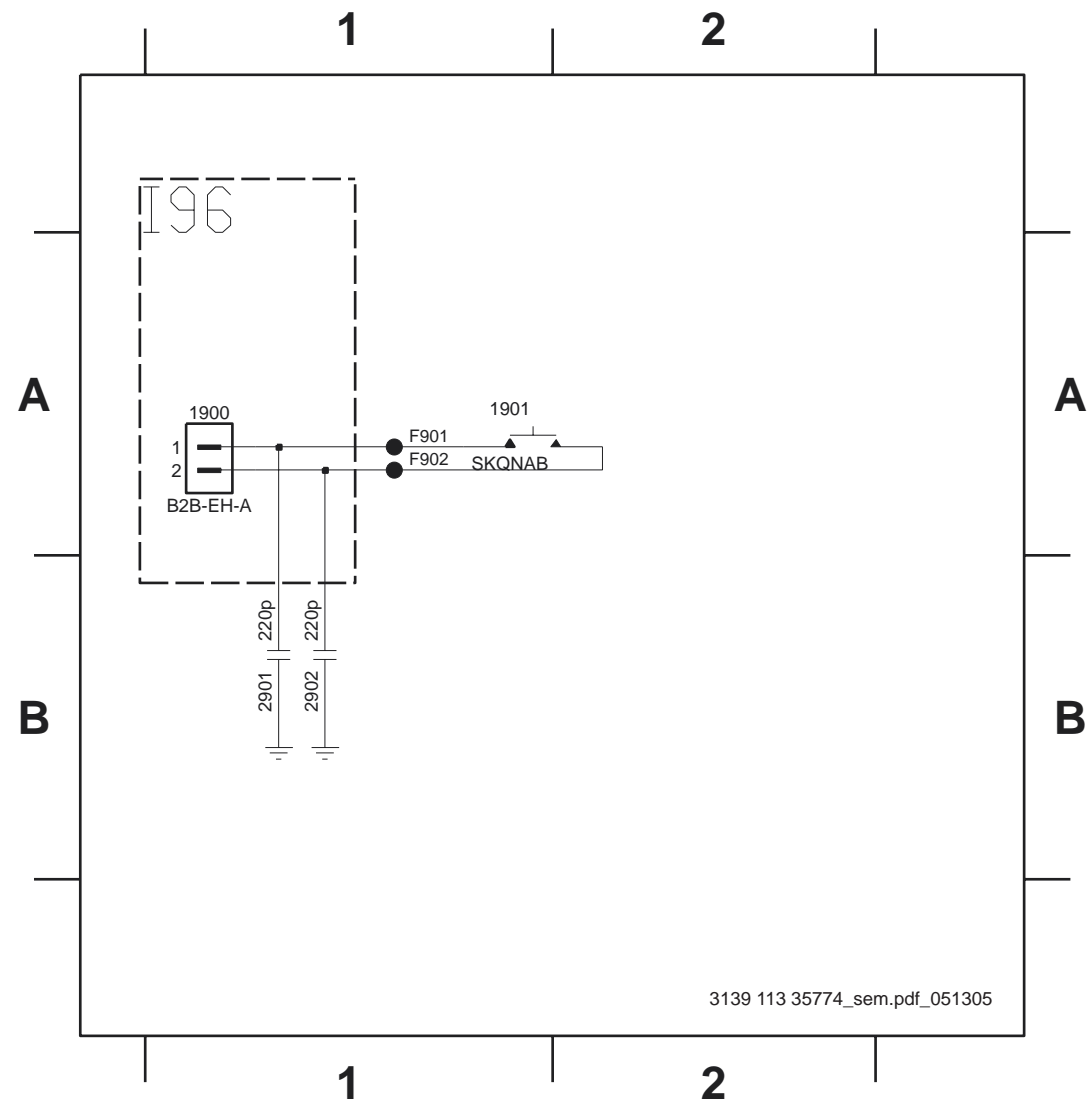

- 1900 A1
- 1901 A1
- 2901 B1
- 2902 B1
- F901 A1
- F902 A1

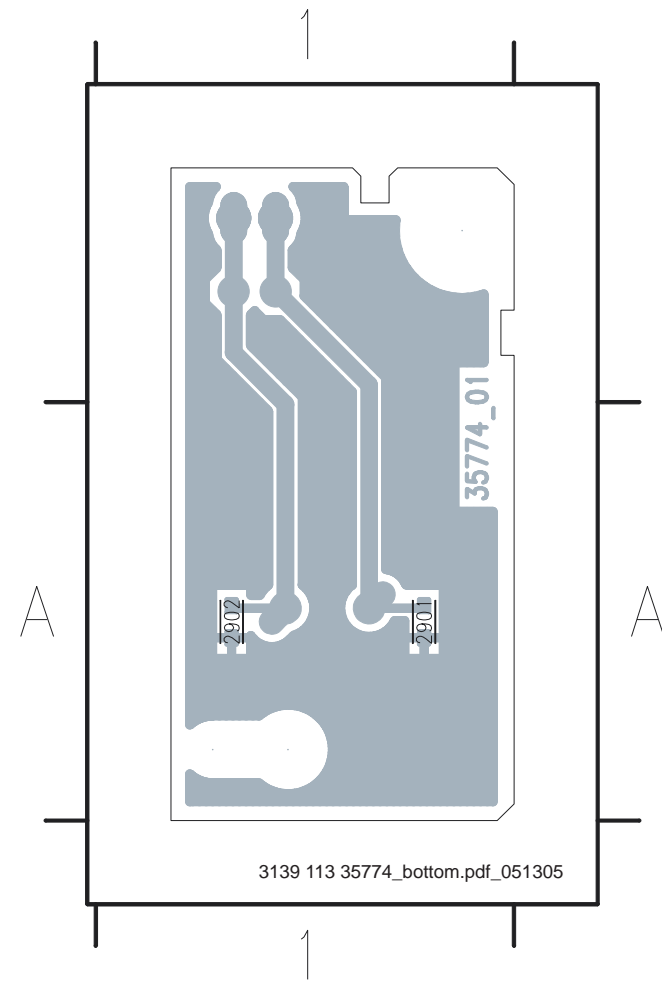

- 2901 A1
- 2902 A1

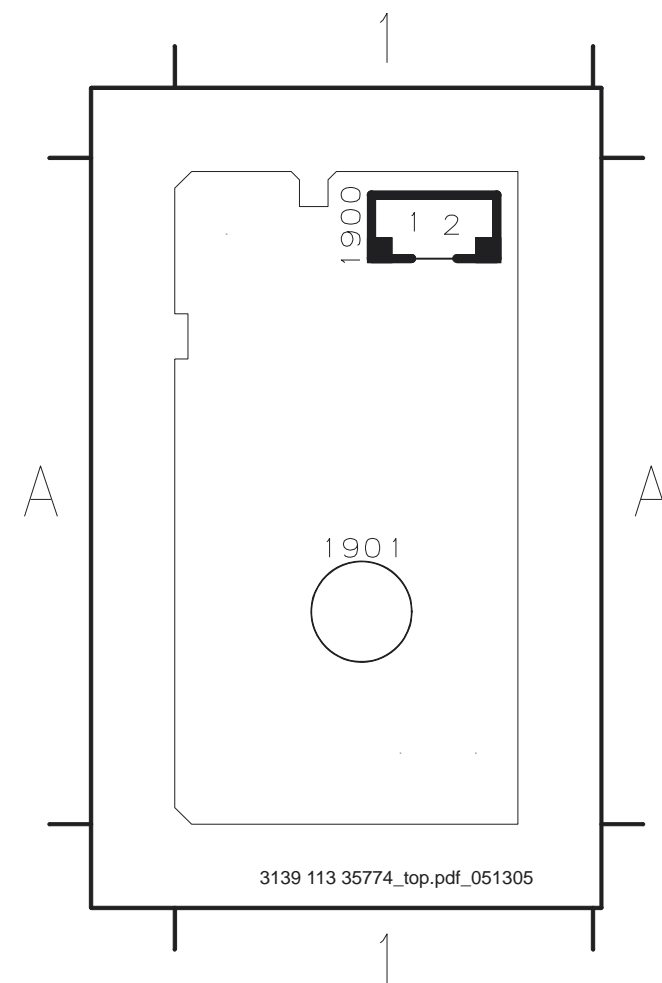

- 1900 A1
- 1901 A1

# Mono Board: Circuit Diagram (Part 1)

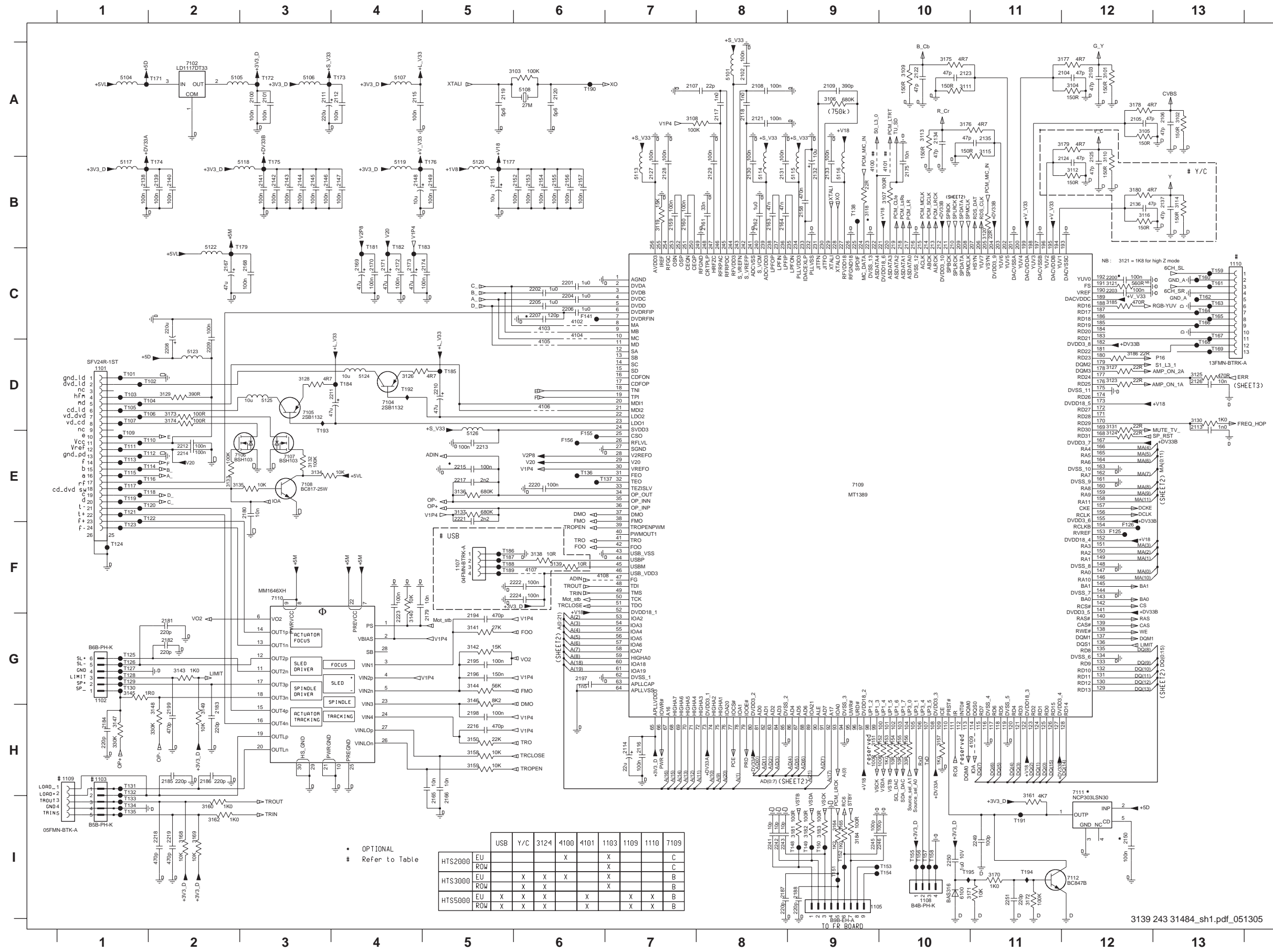

1101 D1	2219 I2	5120 B5
1102 G1	2220 E6	5122 C2
1103 H1	2221 E5	5123 D2
1105 I9	2222 F6	5124 D4
1107 F5	2223 G4	5125 D3
1108 H0	2224 F6	5126 E5
1109 H1	2241 I8	6100 H10
1110 C13	2242 I8	7102 A2
2100 A3	2243 I8	7104 D4
2101 A3	2245 I9	7105 D3
2102 A8	2246 I9	7106 E2
2103 A12	2249 H11	7107 E3
2104 A12	2250 H10	7108 E3
2105 A12	2251 H11	7109 E9
2106 A13	3101 A12	7110 F3
2107 A7	3102 A13	7111 H12
2108 A8	3103 A6	7112 H12
2109 A9	3104 A12	F125 F12
2111 A3	3105 A12	F126 F12
2112 A4	3106 A9	F141 C6
2113 D13	3107 B10	F155 E6
2114 H7	3108 A7	F156 E6
2115 A4	3109 A10	F101 D1
2116 H7	3110 B12	T102 D2
2117 A8	3111 A10	T103 D1
2118 A8	3112 B12	T104 D2
2119 A5	3113 A10	T105 D1
2120 A6	3114 B13	T106 D2
2121 A8	3115 A11	T107 D1
2122 A10	3116 B12	T108 E1
2123 A10	3118 B9	T110 E2
2124 B12	3119 B7	T111 E1
2125 B12	3120 B11	T112 E2
2126 D13	3121 C12	T113 E1
2127 B7	3123 D12	T114 E2
2128 B7	3124 E12	T115 E1
2129 B8	3125 D13	T116 E2
2130 B8	3126 D4	T117 G1
2131 B8	3127 D12	T118 E2
2132 B9	3128 D3	T119 E1
2133 B9	3129 D2	T120 E2
2134 A10	3130 D13	T121 E1
2135 A11	3131 D12	T122 E2
2136 B12	3132 E3	T123 F1
2137 B13	3133 E2	T124 F1
2138 B1	3134 E3	T125 G1
2139 B2	3135 E2	T126 G1
2140 B2	3136 E5	T127 G1
2141 B3	3137 E5	T128 G1
2142 B3	3138 F6	T129 G1
2143 B3	3139 F6	T130 G1
2144 B3	3140 G4	T131 H1
2145 B3	3141 G5	T132 H1
2146 B3	3142 G5	T133 H1
2147 B4	3143 G2	T134 H1
2148 B4	3144 G5	T135 H1
2149 B5	3145 G1	T136 E6
2150 H2	3146 G5	T137 E7
2151 B5	3147 H1	T138 B9
2152 B6	3148 H2	T148 I9
2153 B6	3149 H2	T149 I9
2154 B6	3150 H5	T150 I9
2155 B6	3151 H5	T151 I9
2156 B6	3152 H9	T152 I9
2157 B6	3153 H10	T153 H0
2158 B9	3154 H10	T154 H0
2159 B7	3155 H10	T155 H0
2160 B7	3156 H10	T156 H0
2161 B8	3157 H10	T157 H0
2162 B8	3158 H5	T158 H0
2163 B8	3159 H5	T159 C13
2164 B8	3160 I2	T160 C13
2165 I5	3161 H11	T161 C13
2166 I5	3162 I2	T162 C13
2167 C2	3164 I9	T163 C13
2168 C3	3165 I9	T164 C13
2169 C4	3168 I2	T165 C13
2170 C4	3169 I2	T166 C13
2171 C4	3170 I11	T167 C13
2172 C4	3171 H11	T168 D13
2173 C4	3172 H11	T169 D13
2174 C5	3173 D2	T171 A2
2175 B10	3174 D2	T172 A3
2179 G5	3175 A10	T173 A4
2180 E3	3176 A10	T174 B2
2181 G2	3177 A12	T175 B3
2182 G2	3178 A12	T176 B5
2183 H2	3179 A12	T177 B5
2184 H1	3180 B12	T179 C3
2185 H2	3181 I9	T181 C4
2186 H2	3182 I9	T182 C4
2187 I8	3183 I9	T183 C5
2188 I9	3184 I9	T184 D4
2194 G5	3185 C12	T185 D5
2195 G5	3186 D12	T186 F5
2196 G5	4100 B9	T187 F5
2197 G6	4101 B10	T188 F5
2198 H5	4102 C6	T189 F5
2199 H2	4103 C6	T190 A6
2200 C12	4104 C6	T191 H1
2201 C6	4105 D6	T192 D4
2202 C6	4106 D6	T193 E3
2203 C12	4107 F6	T194 H1
2204 C6	4108 F6	T195 H10
2205 C6	4109 H10	
2206 C6	5101 A8	
2207 C6	5104 A1	
2208 D2	5105 A2	
2209 D2	5106 A3	
2210 D5	5107 A4	
2211 D3	5108 A6	
2212 E2	5113 B7	
2213 E5	5114 B8	
2214 E2	5115 B9	
2215 E5	5116 B9	
2216 E5	5117 B1	
2217 E5	5118 B3	
2218 I2	5119 B4	

OPTIONAL  
# Refer to Table

	USB	Y/C	3124	4100	4101	1103	1109	1110	7109
HTS2000	EU			X		X			C
HTS3000	EU	X	X	X		X			C
HTS5000	EU	X	X	X		X	X	X	B

Mono Board: Circuit Diagram (Part 2)

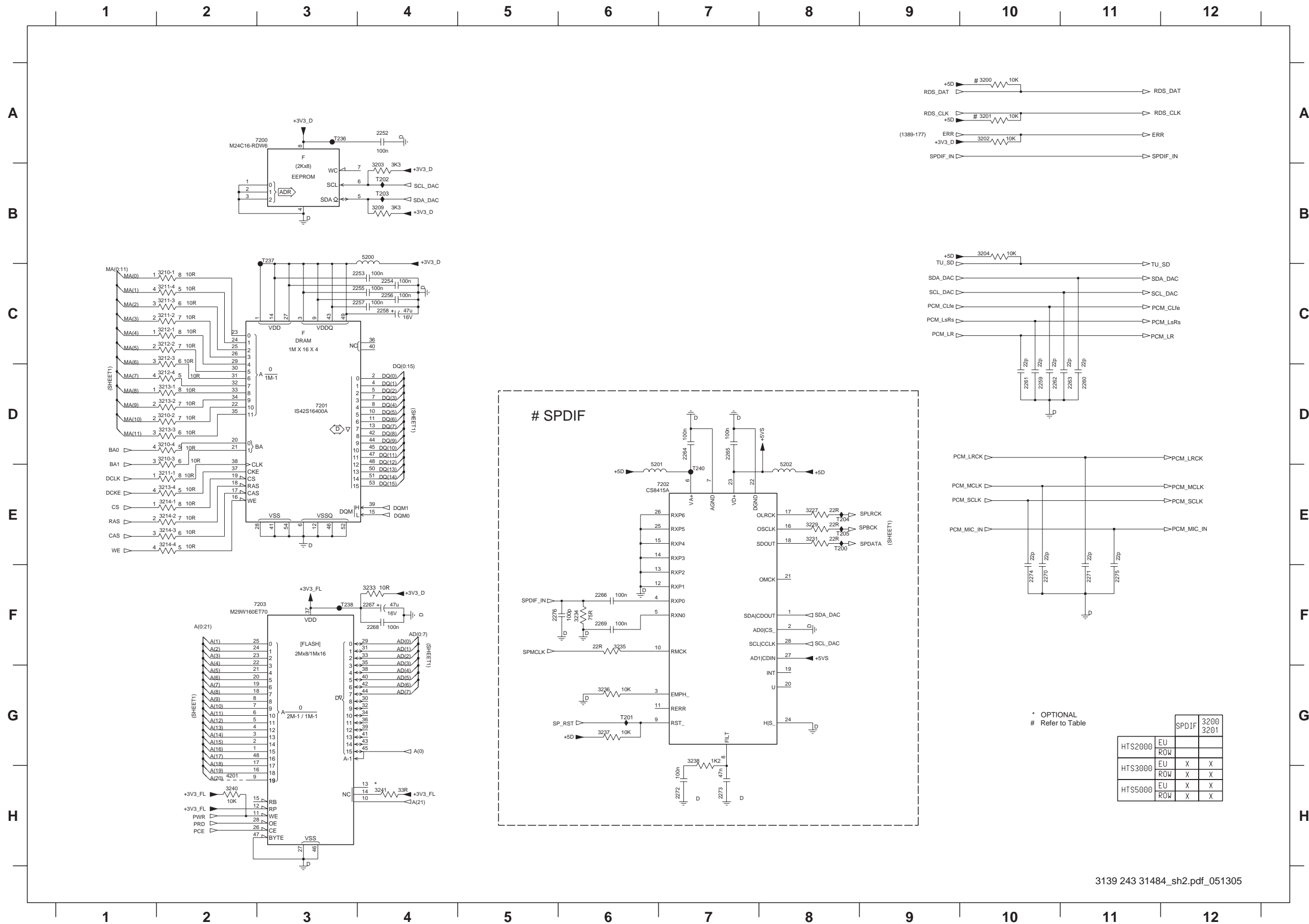

- 2252 A4
- 2253 C4
- 2254 C4
- 2255 C4
- 2256 C4
- 2257 C4
- 2258 C4
- 2259 D10
- 2260 D11
- 2261 D10
- 2262 D10
- 2263 D11
- 2264 D7
- 2265 D7
- 2266 F6
- 2267 F4
- 2268 F4
- 2269 F6
- 2270 F10
- 2271 F11
- 2272 H7
- 2273 H7
- 2274 F10
- 2275 F11
- 2276 F5
- 3200 A10
- 3201 A10
- 3202 A10
- 3203 B4
- 3204 B10
- 3209 B4
- 3210-1 C2
- 3210-2 D2
- 3210-3 D2
- 3210-4 D2
- 3211-1 E2
- 3211-2 C2
- 3211-3 C2
- 3211-4 C2
- 3212-1 C2
- 3212-2 C2
- 3212-3 C2
- 3212-4 D2
- 3213-1 D2
- 3213-2 E2
- 3213-3 D2
- 3213-4 E2
- 3214-1 E2
- 3214-2 E2
- 3214-3 E2
- 3214-4 E2
- 3227 E8
- 3229 E8
- 3231 E8
- 3233 F4
- 3234 F6
- 3235 F6
- 3236 G6
- 3237 G6
- 3238 G7
- 3240 H2
- 3241 H4
- 4201 H2
- 5200 B4
- 5201 E6
- 5202 E8
- 7200 A3
- 7201 D3
- 7202 E7
- 7203 F3
- 7200 E8
- T201 G6
- T202 B4
- T203 B4
- T204 E8
- T205 E8
- T236 A3
- T237 B3
- T238 F3
- T240 E7

Mono Board: Circuit Diagram (Part 3)

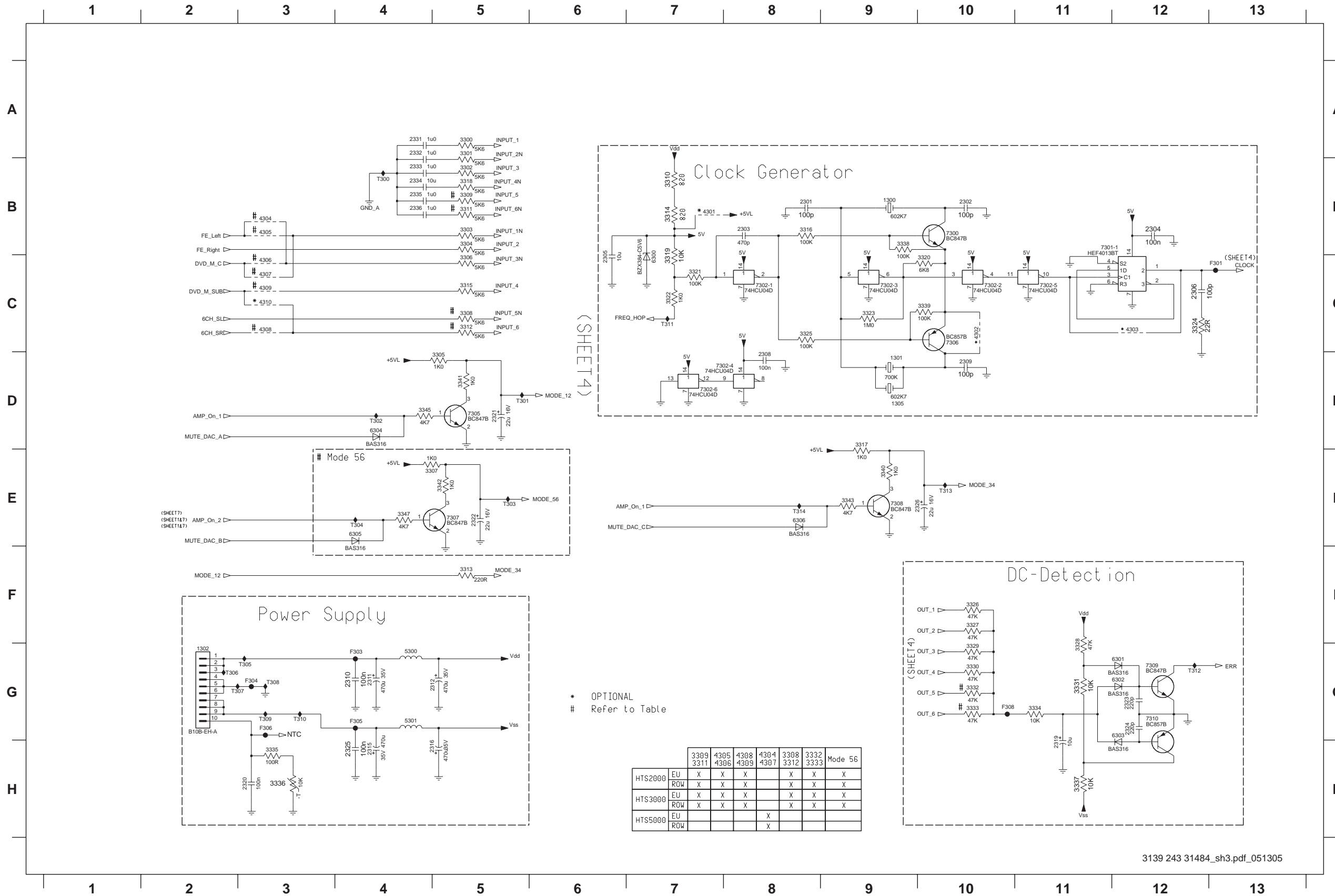

(SHEET 4)

\* OPTIONAL  
# Refer to Table

		3309	4305	4308	4304	3308	3332	Mode 56
HTS2000	EU	X	X	X		X	X	X
	ROW	X	X	X		X	X	X
HTS3000	EU	X	X	X		X	X	X
	ROW	X	X	X		X	X	X
HTS5000	EU				X			
	ROW				X			

- 1300 B9
- 1301 D9
- 1302 G2
- 1305 D9
- 2301 B8
- 2302 B10
- 2303 B8
- 2304 B12
- 2305 C6
- 2306 C12
- 2308 D8
- 2309 D10
- 2310 G4
- 2311 G4
- 2312 G5
- 2315 H4
- 2316 H5
- 2319 H11
- 2320 H3
- 2321 D5
- 2322 E5
- 2323 G12
- 2324 G12
- 2325 H4
- 2326 E10
- 2331 A4
- 2332 A4
- 2333 B4
- 2334 B4
- 2335 B4
- 2336 B4
- 3300 A5
- 3301 A5
- 3302 B5
- 3303 B5
- 3304 B5
- 3305 D5
- 3306 C5
- 3307 E4
- 3308 C5
- 3309 B5
- 3310 B7
- 3311 B5
- 3312 C5
- 3313 F5
- 3314 B7
- 3315 C5
- 3316 B8
- 3317 D9
- 3318 B5
- 3319 C7
- 3320 C10
- 3321 C7
- 3322 C7
- 3323 C9
- 3324 C12
- 3325 C8
- 3326 F10
- 3327 F10
- 3328 G11
- 3329 G10
- 3330 G10
- 3331 G11
- 3332 G10
- 3333 G10
- 3334 G11
- 3335 H3
- 3336 H3
- 3337 H11
- 3338 B9
- 3339 C10
- 3340 E9
- 3341 D5
- 3342 E5
- 3343 E9
- 3345 D4
- 3347 E4
- 4301 B7
- 4302 C10
- 4303 C12
- 4304 B3
- 4305 B3
- 4306 C3
- 4307 C3
- 4308 C3
- 4309 C3
- 4310 C3
- 5300 G4
- 5301 G4
- 6300 C7
- 6301 G12
- 6302 G12
- 6303 G12
- 6304 D4
- 6305 E4
- 6306 E8
- 7300 B10
- 7301-1 B12
- 7302-1 C8
- 7302-2 C10
- 7302-3 C9
- 7302-4 D8
- 7302-5 C11
- 7302-6 D7
- 7305 D5
- 7306 C10
- 7307 E5
- 7308 E9
- 7309 G12
- 7310 G12
- 7311 C13
- 7312 G12
- 7313 G12
- 7314 E8

Mono Board: Circuit Diagram (Part 4)

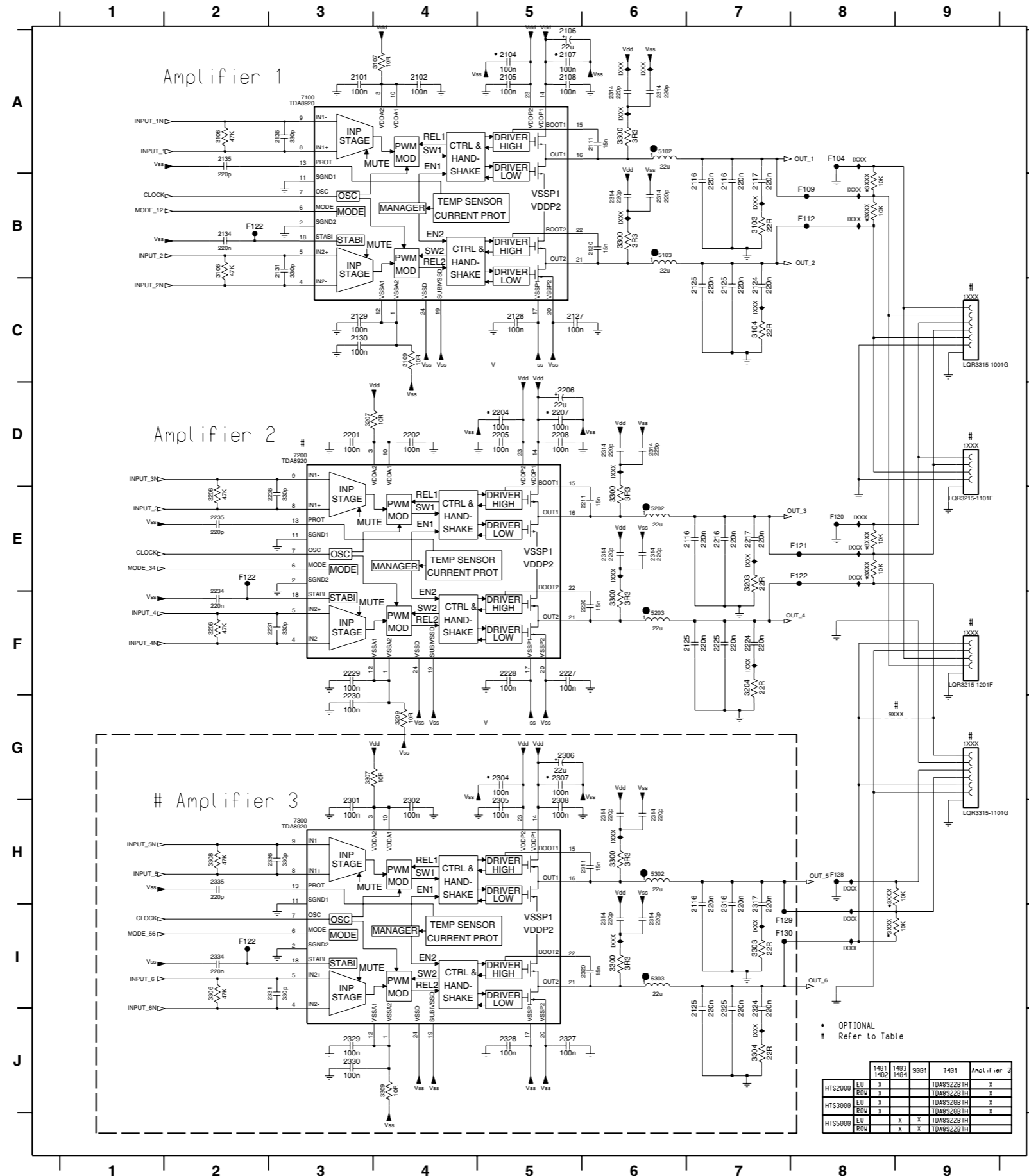

- 1401 G9 F405 E8
- 1402 C9 F406 E8
- 1403 F9 F407 E8
- 1404 D9 F409 H8
- 2314 H6 F410 I7
- 2400 A5 F411 I7
- 2401 A5 F415 B2
- 2402 A5 F415 E2
- 2403 A3 F417 I2
- 2404 A4 T400 A8
- 2405 A5 T401 B8
- 2406 A5 T402 B8
- 2407 A3 T403 E8
- 2408 A6 T404 E8
- 2409 A6 T405 E8
- 2411 A2 T406 H8
- 2412 A6 T407 B8
- 2413 B7 T408 B8
- 2414 B7 T409 A6
- 2415 B2 T410 A6
- 2416 B6 T411 A6
- 2417 B6 T412 B6
- 2418 B3 T413 B7
- 2420 B6 T414 C7
- 2421 C7 T415 D6
- 2422 C7 T416 E6
- 2423 C3 T417 E7
- 2424 C5 T418 F7
- 2425 C5 T419 H6
- 2426 C3 T420 H5
- 2427 D5 T421 I7
- 2428 D5 T422 J7
- 2429 D5
- 2430 D3
- 2431 D4
- 2432 D5
- 2433 D5
- 2434 E3
- 2435 D6
- 2436 E6
- 2438 E2
- 2439 D6
- 2440 E7
- 2441 E7
- 2442 F2
- 2443 E6
- 2444 F6
- 2445 F3
- 2447 E6
- 2448 F7
- 2449 F7
- 2450 F3
- 2451 F5
- 2452 F5
- 2453 G3
- 2454 G5
- 2455 G5
- 2456 G5
- 2457 H3
- 2458 H4
- 2459 H5
- 2460 H5
- 2461 H3
- 2463 H6
- 2465 H2
- 2466 H6
- 2467 I7
- 2468 I7
- 2469 I2
- 2470 I6
- 2471 I6
- 2472 I3
- 2474 I6
- 2475 J7
- 2476 J7
- 2477 J3
- 2478 J5
- 2479 J5
- 2480 J3
- 2481 B7
- 2482 C7
- 2483 E7
- 2484 F7
- 2485 I7
- 2486 J7
- 3400 A4
- 3401 A6
- 3402 A2
- 3403 B6
- 3404 B8
- 3405 B7
- 3406 B2
- 3407 B8
- 3408 C7
- 3409 C4
- 3410 D3
- 3411 E6
- 3412 E2
- 3413 F6
- 3414 E8
- 3415 E7
- 3416 F2
- 3417 E8
- 3418 F7
- 3419 G4
- 3420 G3
- 3421 H6
- 3422 H2
- 3423 I6
- 3424 H8
- 3425 I7
- 3426 I2
- 3427 B8
- 3428 J7
- 3429 J4
- 5400 A6
- 5401 B6
- 5402 E6
- 5403 F6
- 5404 H6
- 5405 I6
- 7400 A3
- 7401 D3
- 7402 H3
- 9001 G9
- F401 A8
- F402 B8
- F403 B8

OPTIONAL  
# Refer to Table

	1401	1403	9001	1401	Amplifier 3
HTS2008	EU	X		TDA8922BTH	X
	ROW	X		TDA8922BTH	X
HTS3008	EU	X		TDA8920BTH	X
	ROW	X		TDA8920BTH	X
HTS5008	EU	X	X	TDA8922BTH	X
	ROW	X	X	TDA8922BTH	X

# Mono Board: Circuit Diagram (Part 5)

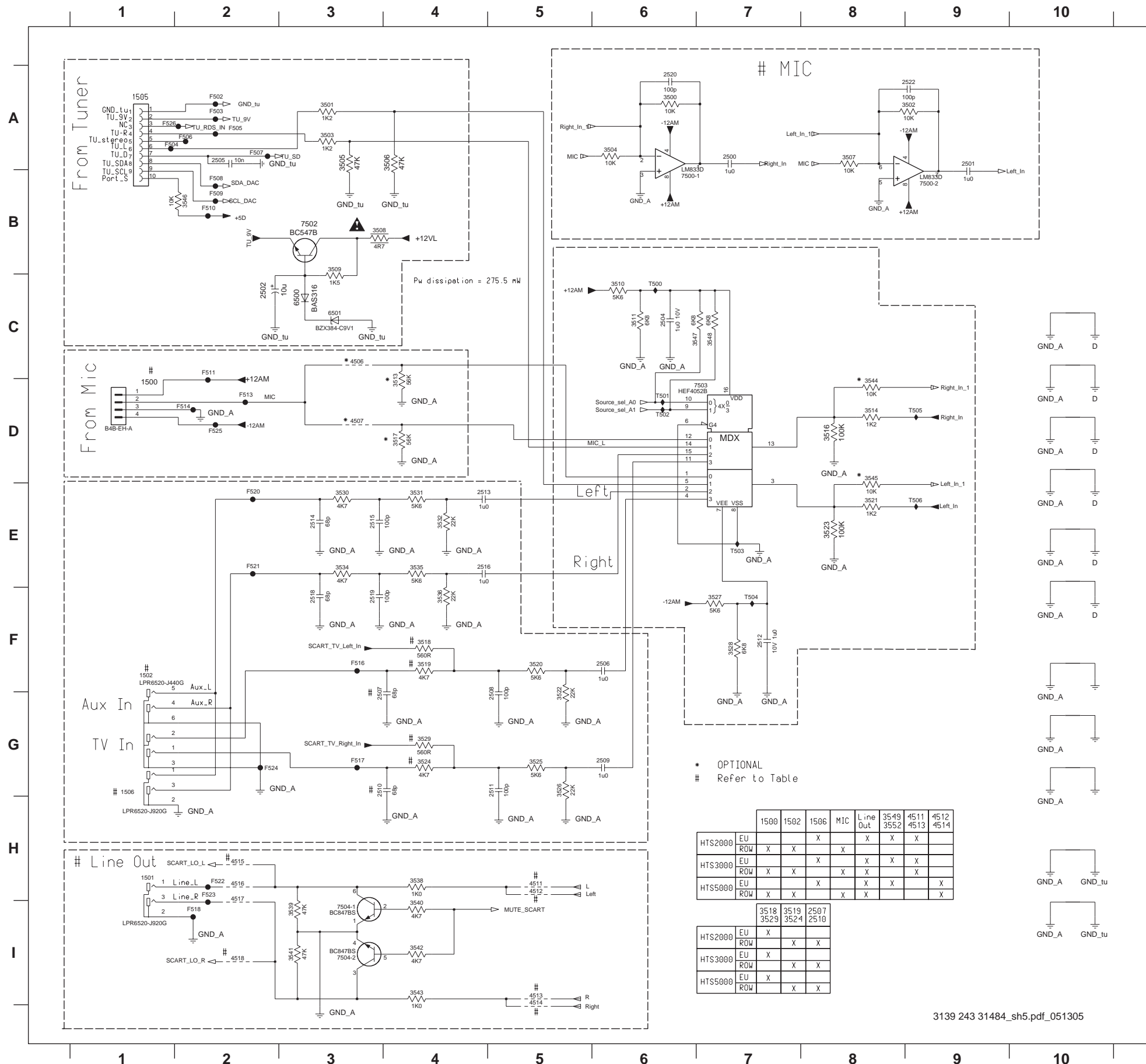

\* OPTIONAL  
# Refer to Table

		1500	1502	1506	MIC	Line Out	3549	4511	4512
HTS2000	EU	X	X	X	X	X	X	X	
HTS3000	EU	X	X	X	X	X	X	X	
HTS5000	EU	X	X	X	X	X	X	X	X

		3518	3519	2507
HTS2000	EU	X		
HTS3000	EU	X	X	X
HTS5000	EU	X	X	X

- 1500 D1
- 1501 H1
- 1502 F1
- 1506 G1
- 2500 A7
- 2501 A9
- 2502 C2
- 2504 C6
- 2505 A2
- 2506 F6
- 2507 G3
- 2508 G5
- 2509 G6
- 2510 G3
- 2511 G5
- 2512 F7
- 2513 E4
- 2514 E3
- 2515 E3
- 2516 E4
- 2518 F3
- 2519 F3
- 2520 A6
- 2522 A9
- 3500 A6
- 3501 A3
- 3502 A9
- 3503 A3
- 3504 A6
- 3505 A3
- 3506 A4
- 3507 A8
- 3508 B3
- 3509 B3
- 3510 C6
- 3511 C6
- 3513 D4
- 3514 D8
- 3516 D8
- 3517 D4
- 3518 F4
- 3519 F4
- 3520 F5
- 3521 E8
- 3522 G5
- 3523 E8
- 3524 G4
- 3525 G5
- 3526 G5
- 3527 F7
- 3528 F7
- 3529 G4
- 3530 E3
- 3531 E4
- 3532 E4
- 3533 E3
- 3535 E4
- 3536 F4
- 3538 H4
- 3539 I3
- 3540 I4
- 3541 I3
- 3542 I4
- 3543 I4
- 3544 D8
- 3545 D8
- 3546 B2
- 3547 C7
- 3548 C7
- 4506 C3
- 4507 D3
- 4511 H5
- 4512 H5
- 4513 I5
- 4514 I5
- 4515 H2
- 4516 H2
- 4517 H2
- 4518 I2
- 6500 C3
- 6501 C3
- 7500-1 B6
- 7500-2 B9
- 7502 B3
- 7503 D7
- 7504-1 I3
- 7504-2 I3
- F502 A2
- F503 A2
- F504 A1
- F505 A2
- F506 A2
- F507 A2
- F508 B2
- F509 B2
- F510 B2
- F511 C2
- F512 D2
- F514 D2
- F516 F3
- F517 G3
- F518 I2
- F520 E2
- F521 E2
- F522 H2
- F523 H2
- F524 G2
- F525 D2
- F526 A1
- T500 C6
- T501 D6
- T502 D6
- T503 E7
- T504 F7
- T505 D9
- T506 E9

# Mono Board: Circuit Diagram (Part 6)

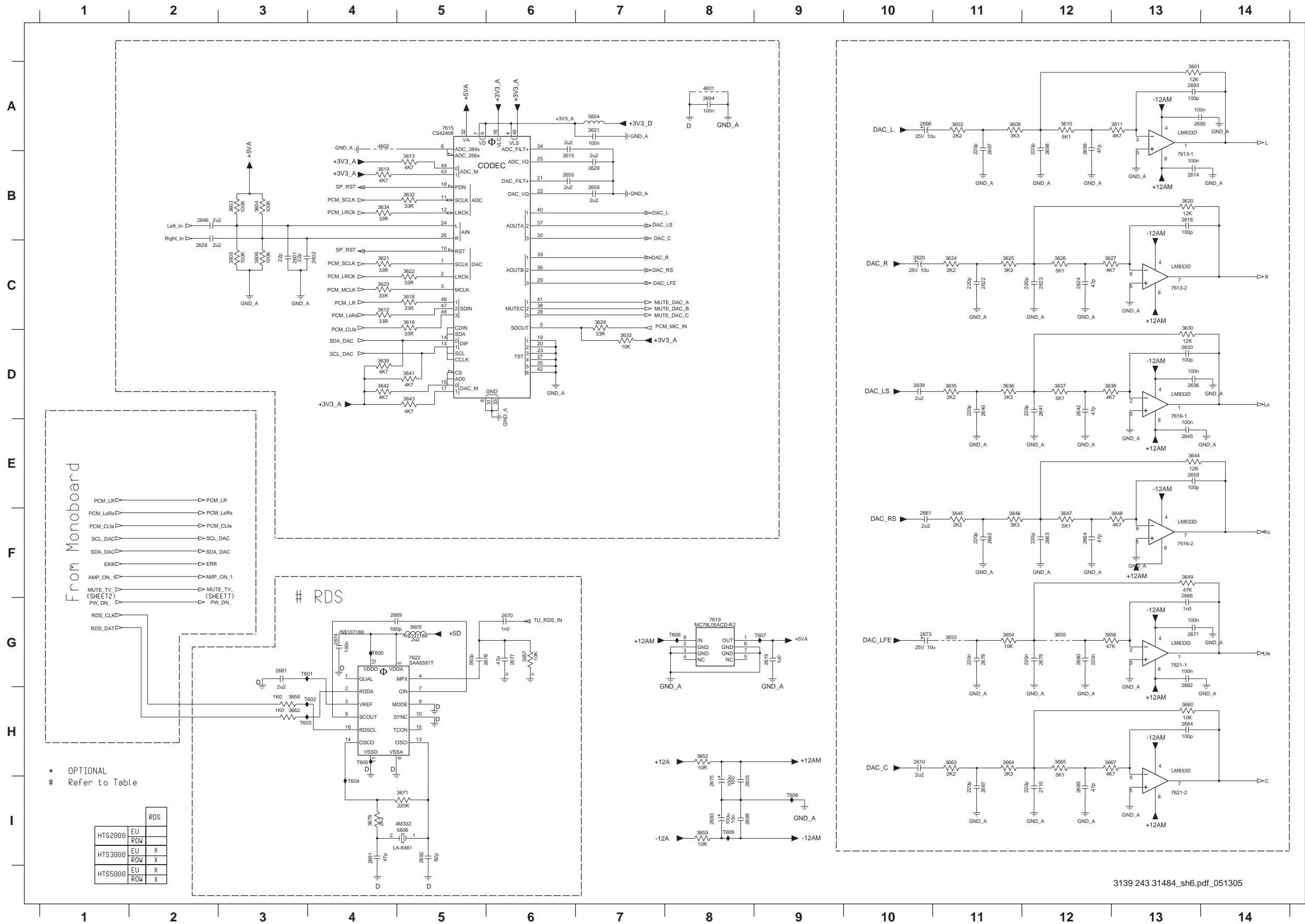

- 2110 H12
- 2601 C3
- 2602 C4
- 2603 I8
- 2610 H10
- 2614 B13
- 2615 B6
- 2616 B13
- 2619 G9
- 2620 C10
- 2621 A7
- 2622 C11
- 2623 C12
- 2624 C12
- 2628 C2
- 2629 B7
- 2630 D13
- 2636 D13
- 2639 D10
- 2640 D11
- 2641 D12
- 2642 D12
- 2645 E13
- 2646 B2
- 2655 B6
- 2658 B7
- 2659 E13
- 2671 F10
- 2662 F11
- 2663 F12
- 2664 F12
- 2666 G13
- 2669 G4
- 2670 G6
- 2671 C13
- 2673 G10
- 2674 G4
- 2675 I8
- 2676 G5
- 2677 G6
- 2678 G11
- 2679 D12
- 2680 H12
- 2681 G3
- 2682 G13
- 2683 I8
- 2684 H13
- 2687 H1
- 2688 I8
- 2689 I2
- 2691 I4
- 2692 I5
- 2693 A13
- 2694 A8
- 2695 A13
- 2696 A10
- 2697 A11
- 2698 A12
- 2699 A12
- 3601 A13
- 3602 A11
- 3603 B3
- 3604 B3
- 3605 C3
- 3606 C3
- 3609 A11
- 3610 A12
- 3611 A13
- 3612 C4
- 3613 B5
- 3616 C5
- 3618 C5
- 3619 B4
- 3620 B13
- 3621 C4
- 3622 C5
- 3623 C4
- 3624 C11
- 3625 C11
- 3626 C12
- 3627 C12
- 3628 C7
- 3630 D13
- 3632 B5
- 3633 D7
- 3634 B4
- 3635 D11
- 3636 D11
- 3637 D12
- 3638 D12
- 3639 D4
- 3641 D5
- 3642 D4
- 3643 D5
- 3644 E13
- 3645 F11
- 3646 F11
- 3647 F12
- 3648 F13
- 3649 F13
- 3652 H8
- 3653 C11
- 3654 G11
- 3655 G12
- 3656 G12
- 3657 G6
- 3658 H3
- 3659 I8
- 3660 H13
- 3662 H3
- 3663 H11
- 3664 H11
- 3665 H12
- 3667 H12
- 3671 I5
- 3678 I4
- 4601 A4
- 5604 A7
- 5605 G5
- 5606 I5
- 7613-1 B13
- 7613-2 C13
- 7615 A5
- 7616-1 D13
- 7616-2 F13
- 7619 G8
- 7621-1 G13
- 7621-2 H13
- 7622 G5
- T600 G4
- T601 G3
- T602 H4
- T603 I4
- T604 I5
- T605 I5
- T606 I8
- T607 I8
- T608 I8
- T609 I8



Mono Board: Circuit Diagram (Part 7)

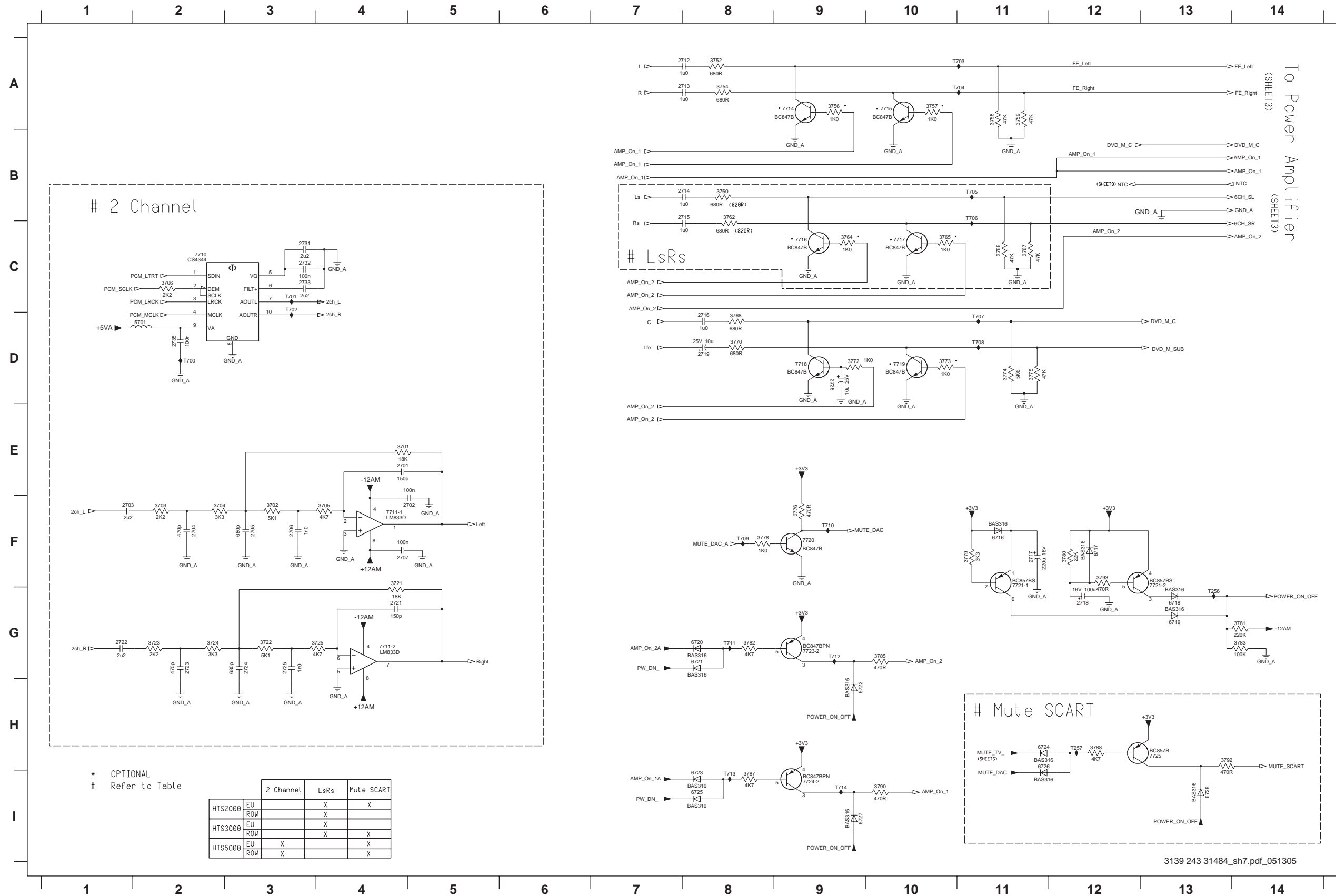

• OPTIONAL  
# Refer to Table

		2 Channel	LsRs	Mute SCART
HTS2000	EU	X	X	X
	ROW		X	
HTS3000	EU	X	X	X
	ROW		X	
HTS5000	EU	X	X	X
	ROW	X		X

- 2701 E4
- 2702 F5
- 2703 F1
- 2704 F2
- 2705 F3
- 2706 F3
- 2707 F4
- 2712 A8
- 2713 A8
- 2714 B8
- 2715 B8
- 2716 D8
- 2717 F11
- 2718 G12
- 2719 D8
- 2721 G4
- 2722 G1
- 2723 G2
- 2724 G3
- 2725 G3
- 2726 D9
- 2731 C3
- 2732 C3
- 2733 C3
- 2735 D2
- 3701 E4
- 3702 F3
- 3703 F2
- 3704 F2
- 3705 F4
- 3706 C2
- 3721 F4
- 3722 G3
- 3723 G2
- 3724 G2
- 3725 G4
- 3752 A8
- 3754 A8
- 3756 A9
- 3757 A10
- 3758 A11
- 3759 A11
- 3760 B8
- 3762 B8
- 3764 C9
- 3765 C10
- 3766 C11
- 3767 C11
- 3768 D8
- 3770 D8
- 3772 D9
- 3773 D10
- 3774 D11
- 3775 D11
- 3776 F9
- 3778 F8
- 3779 F11
- 3780 F12
- 3781 G14
- 3782 G8
- 3783 G14
- 3785 G10
- 3787 I8
- 3788 H12
- 3790 I10
- 3792 H13
- 3793 F12
- 5701 D2
- 6716 F11
- 6717 F12
- 6718 G13
- 6719 G13
- 6720 G8
- 6721 G8
- 6722 H9
- 6723 I8
- 6724 H11
- 6725 I8
- 6726 H11
- 6727 I9
- 6728 I13
- 7710 C2
- 7711-1 F4
- 7711-2 G4
- 7714 A9
- 7715 A10
- 7716 C9
- 7717 C10
- 7718 D9
- 7719 D10
- 7720 F9
- 7721-1 F11
- 7721-2 F13
- 7723-2 G9
- 7724-2 I9
- 7725 H13
- 7725 H13
- T256 G13
- T257 H12
- T700 D2
- T701 C3
- T702 C3
- T703 A8
- T704 A8
- T705 C9
- T706 C9
- T707 D9
- T708 D9
- T709 F9
- T710 F9
- T711 G9
- T712 G9
- T713 G9
- T714 G9
- T715 G9
- T716 G9
- T717 G9
- T718 G9
- T719 G9
- T720 G9
- T721 G9
- T722 G9
- T723 G9
- T724 G9
- T725 G9
- T726 G9
- T727 G9
- T728 G9
- T729 G9
- T730 G9
- T731 G9
- T732 G9
- T733 G9
- T734 G9
- T735 G9
- T736 G9
- T737 G9
- T738 G9
- T739 G9
- T740 G9
- T741 G9
- T742 G9
- T743 G9
- T744 G9
- T745 G9
- T746 G9
- T747 G9
- T748 G9
- T749 G9
- T750 G9
- T751 G9
- T752 G9
- T753 G9
- T754 G9
- T755 G9
- T756 G9
- T757 G9
- T758 G9
- T759 G9
- T760 G9
- T761 G9
- T762 G9
- T763 G9
- T764 G9
- T765 G9
- T766 G9
- T767 G9
- T768 G9
- T769 G9
- T770 G9
- T771 G9
- T772 G9
- T773 G9
- T774 G9
- T775 G9
- T776 G9
- T777 G9
- T778 G9
- T779 G9
- T780 G9
- T781 G9
- T782 G9
- T783 G9
- T784 G9
- T785 G9
- T786 G9
- T787 G9
- T788 G9
- T789 G9
- T790 G9
- T791 G9
- T792 G9
- T793 G9
- T794 G9
- T795 G9
- T796 G9
- T797 G9
- T798 G9
- T799 G9
- T800 G9

Mono Board: Circuit Diagram (Part 8)

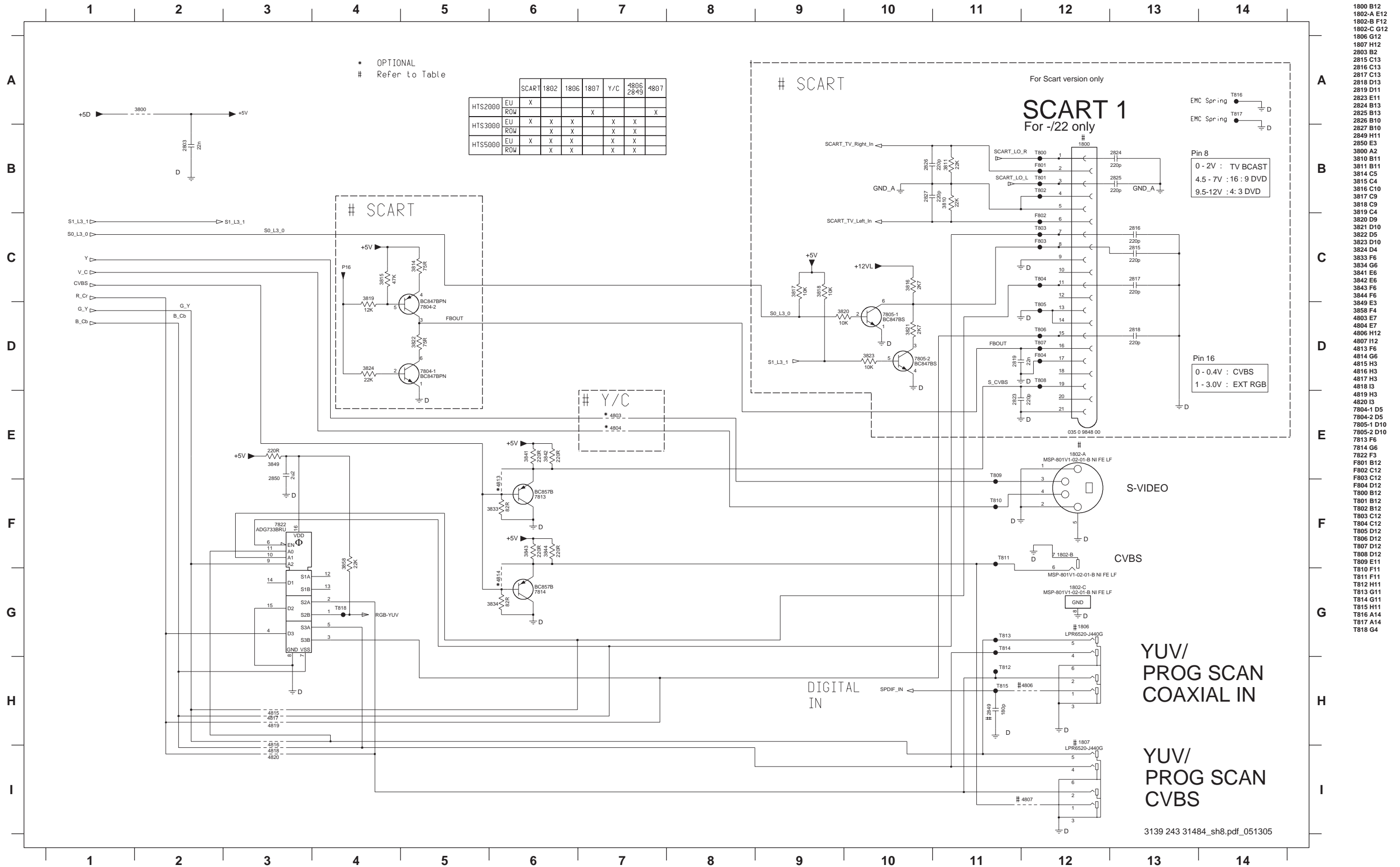

- 1800 B12
- 1802-A E12
- 1802-B F12
- 1802-C G12
- 1806 G12
- 1807 H12
- 2803 B2
- 2815 C13
- 2816 C13
- 2817 C13
- 2818 D13
- 2819 D11
- 2823 E11
- 2824 B13
- 2825 B13
- 2826 B10
- 2827 B10
- 2849 H11
- 2850 E3
- 3800 A2
- 3810 B11
- 3811 B11
- 3814 C5
- 3815 C4
- 3816 C10
- 3817 C9
- 3818 C9
- 3819 C4
- 3820 D9
- 3821 D10
- 3822 D5
- 3823 D10
- 3824 D4
- 3833 F6
- 3834 G6
- 3841 E6
- 3842 E6
- 3843 F6
- 3844 F6
- 3849 E3
- 3858 F4
- 4803 E7
- 4804 E7
- 4806 H12
- 4807 H12
- 4813 F6
- 4814 G6
- 4815 H3
- 4816 H3
- 4817 H3
- 4818 I3
- 4819 H3
- 4820 I3
- 7804-1 D5
- 7804-2 D5
- 7805-1 D10
- 7805-2 D10
- 7813 F6
- 7814 G6
- 7822 F3
- F801 B12
- F802 C12
- F803 C12
- F804 D12
- T800 B12
- T801 B12
- T802 B12
- T803 C12
- T804 C12
- T805 D12
- T806 D12
- T807 D12
- T808 D12
- T809 E11
- T810 F11
- T811 F11
- T812 H11
- T813 G11
- T814 G11
- T815 H11
- T816 A14
- T817 A14
- T818 G4

Mono Board: Circuit Diagram (Part 9)

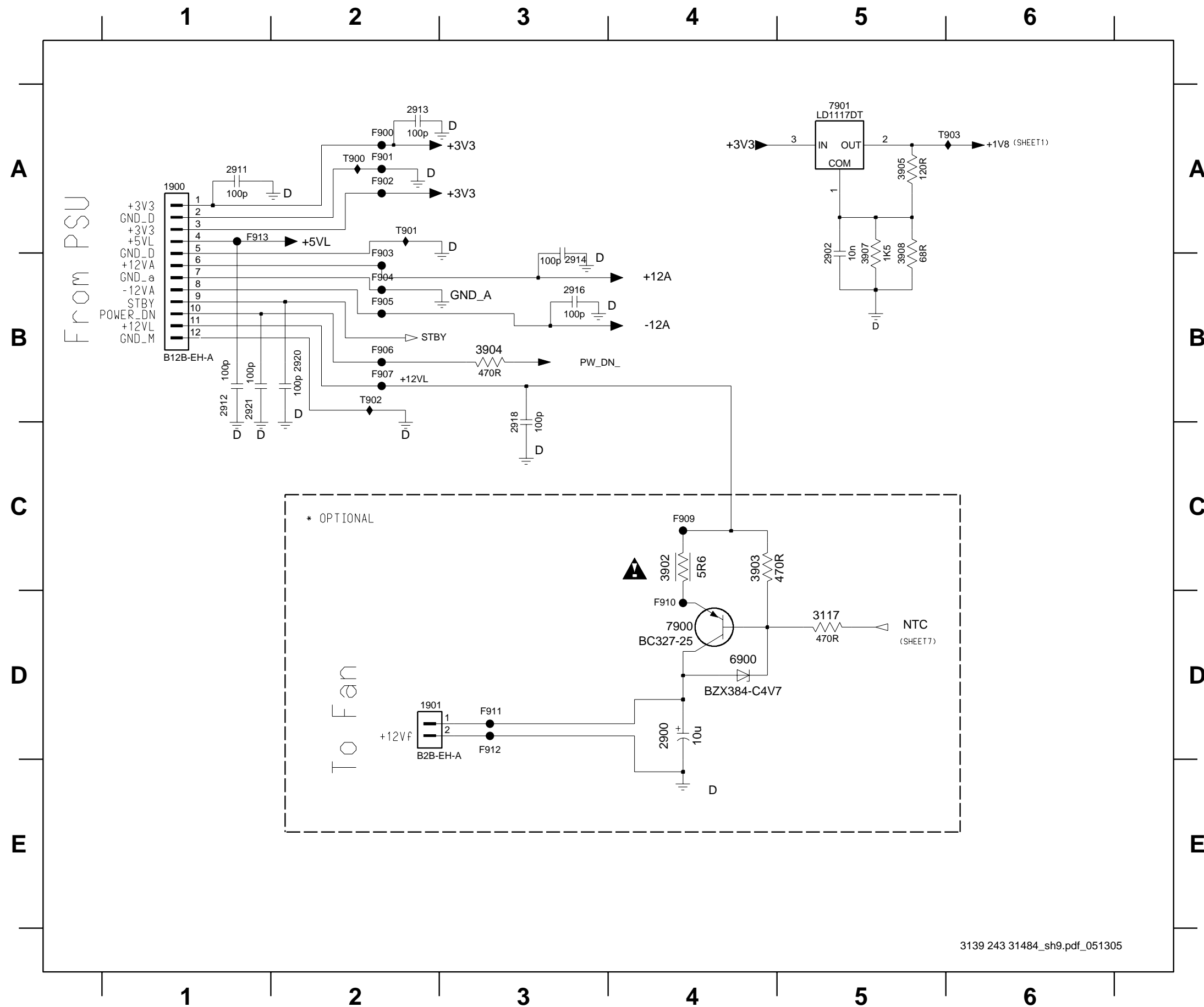

- 1900 A1
- 1901 D2
- 2900 D4
- 2902 B5
- 2911 A1
- 2912 B1
- 2913 A2
- 2914 B3
- 2916 B3
- 2918 C3
- 2920 B2
- 2921 B1
- 3107 D5
- 3902 C4
- 3903 C4
- 3904 B3
- 3905 A5
- 3907 B5
- 3908 B5
- 6900 D4
- 7900 D4
- 7901 A5
- F900 A2
- F901 A2
- F902 A2
- F903 B2
- F904 B2
- F905 B2
- F906 B2
- F907 B2
- F909 C4
- F910 D4
- F911 D3
- F912 D3
- F913 A1
- T900 A2
- T901 A2
- T902 B2
- T903 A6

### Layout: Mono Board (Topview)

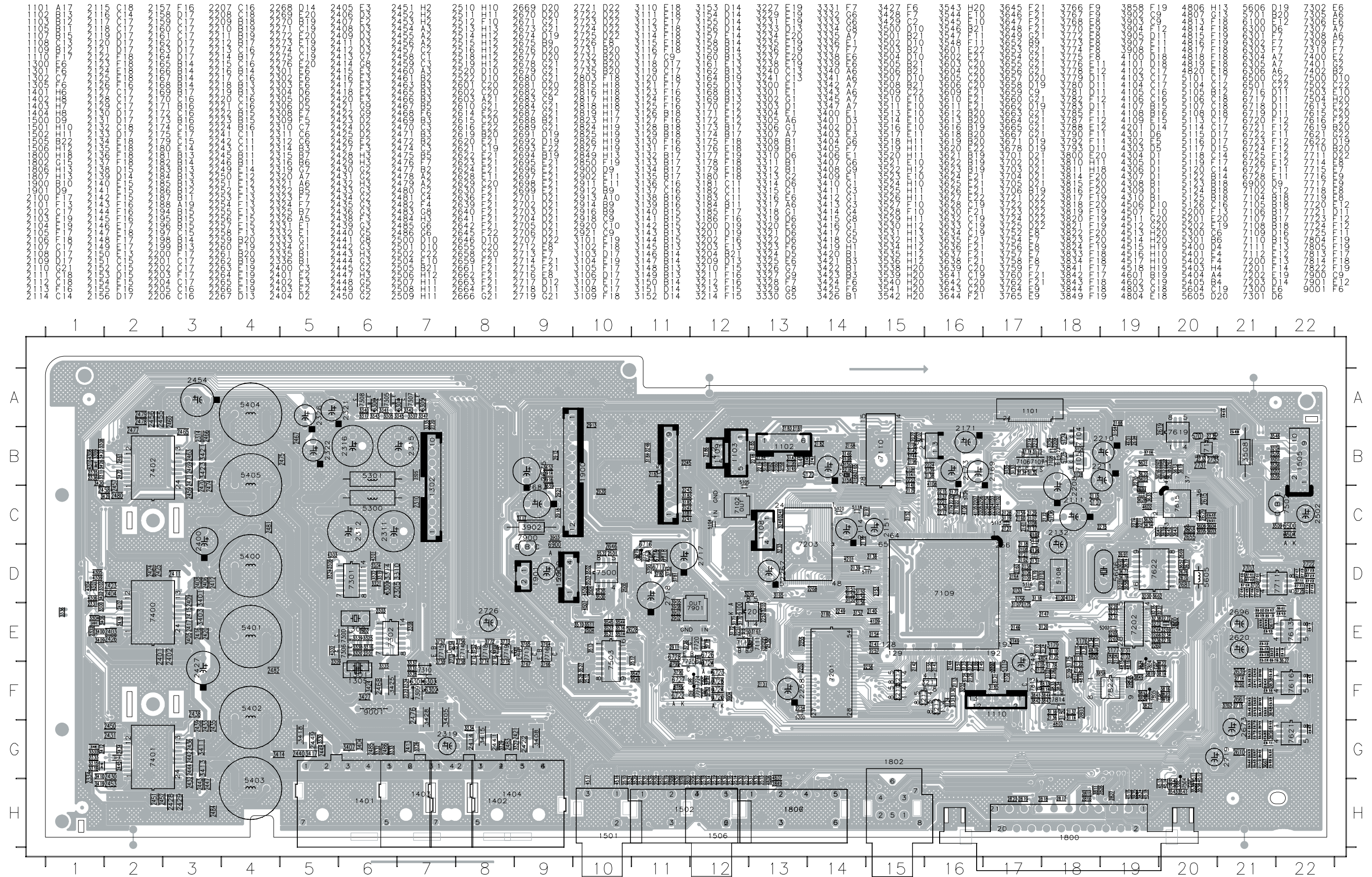

Layout: Mono Board (Bottom view)

1102 B13 1108 C13 1301 F6 1402 H8 1501 H10 1800 H18 1900 B10 2132 C18 2169 B17 2210 B19 2311 C6 2319 G7 2400 C3 2620 E21 2696 E21 2726 E8 5300 C6 5402 F4 5605 D20 9001 F6  
 1103 B12 1109 B12 1302 F7 1403 H7 1502 H11 1801 G18 1901 D9 2133 C17 2171 B17 2211 B19 2312 C6 2321 A6 2427 F3 2621 E21 2697 E21 2727 E8 5301 B6 5403 H4 5606 D19  
 1105 B15 1110 E6 1305 F6 1404 H8 1505 H12 1802 H15 1911 C18 2134 C18 2173 B17 2212 B19 2313 B6 2322 B5 2454 A3 2673 B9 2698 D11 2728 D9 5302 D4 5404 A4 5607 C22  
 1107 B15 1300 E6 1401 H6 1500 D9 1807 H13 2114 C14 2167 B14 2208 C18 2226 D13 2316 B6 2326 A5 2502 C22 2683 C9 2719 G21 3902 C9 5401 E4 5405 B4 7900 C9

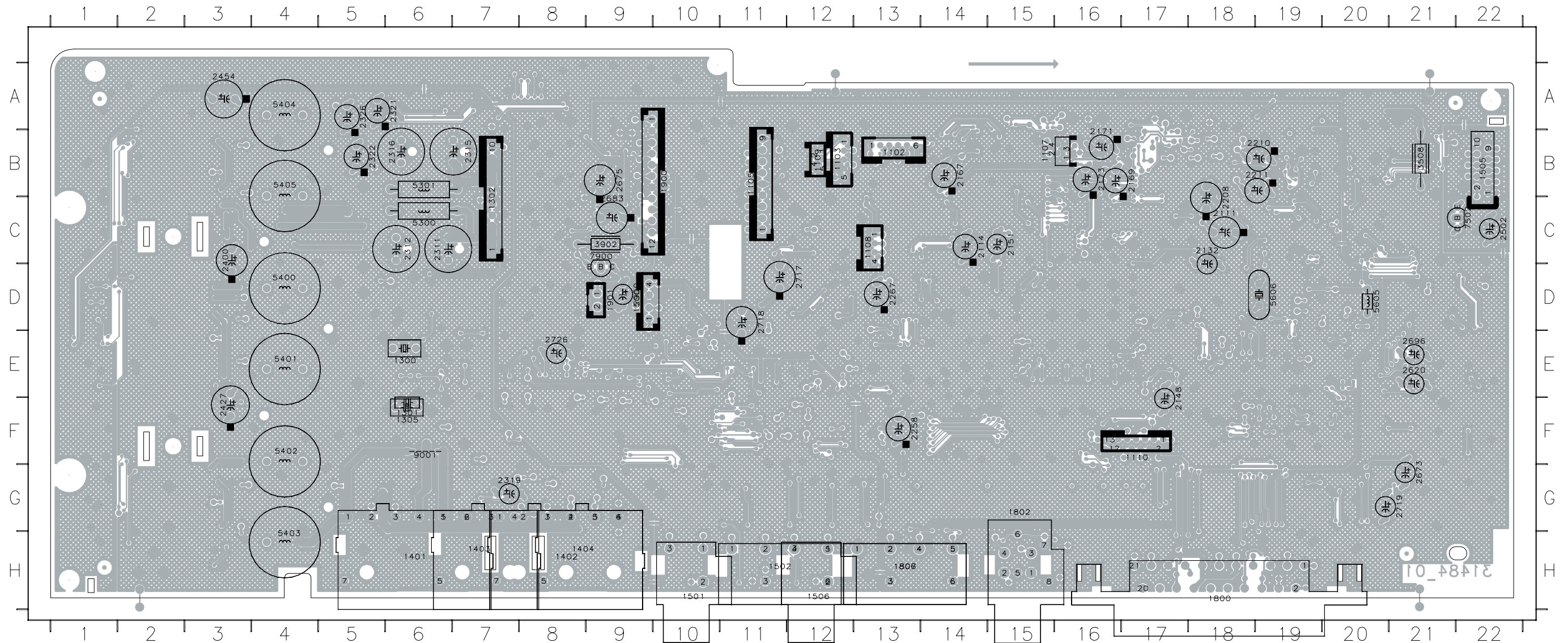

# PSU Circuit Diagram (For information only)

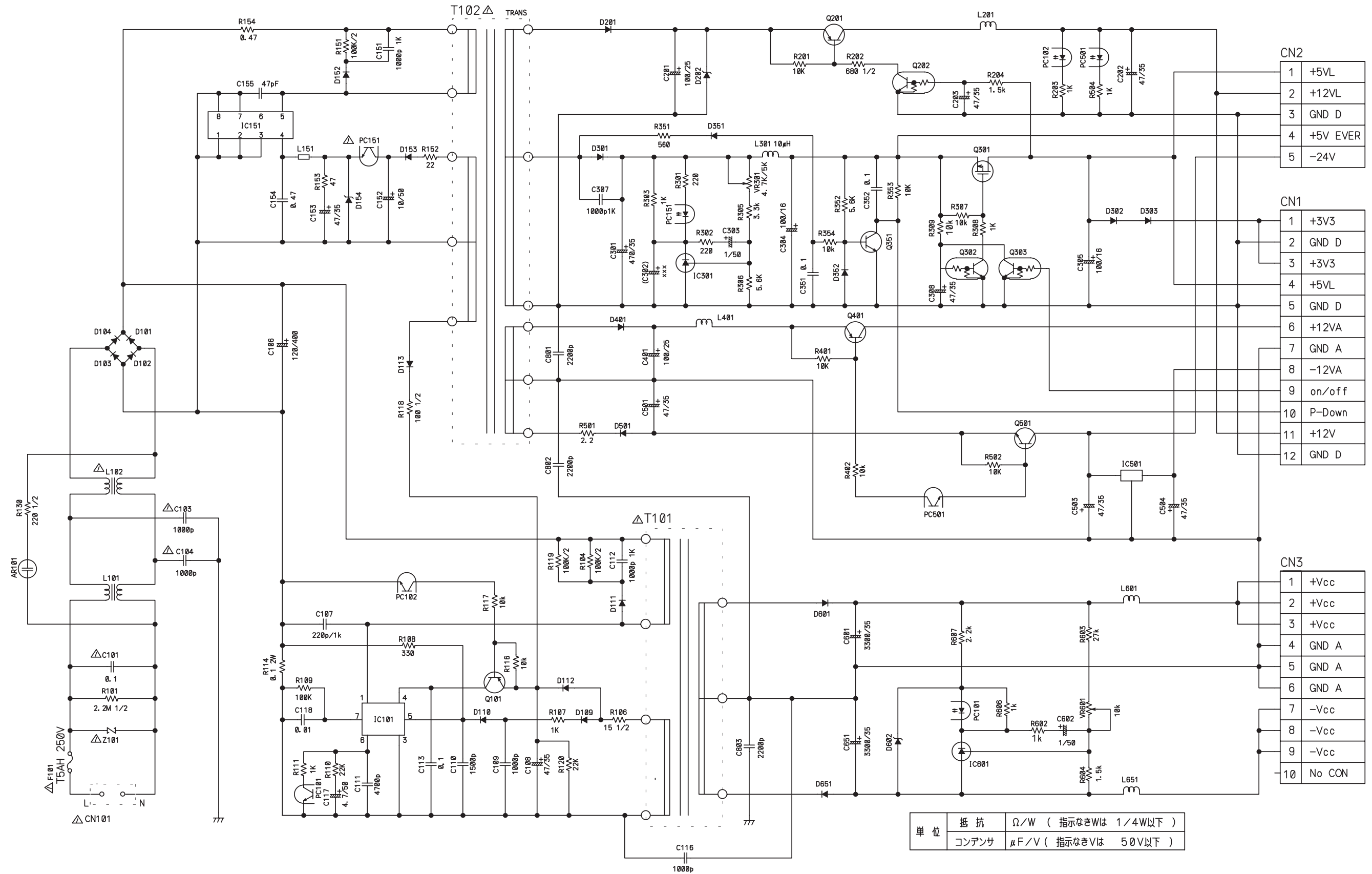

単位	抵抗	Ω/W (指示なきWは 1/4W以下)
	コンデンサ	μF/V (指示なきVは 50V以下)

CN2

1	+5VL
2	+12VL
3	GND D
4	+5V EVER
5	-24V

CN1

1	+3V3
2	GND D
3	+3V3
4	+5VL
5	GND D
6	+12VA
7	GND A
8	-12VA
9	on/off
10	P-Down
11	+12V
12	GND D

CN3

1	+Vcc
2	+Vcc
3	+Vcc
4	GND A
5	GND A
6	GND A
7	-Vcc
8	-Vcc
9	-Vcc
10	No CON

( ) : no stuff

### 9. Exploded View of the Set

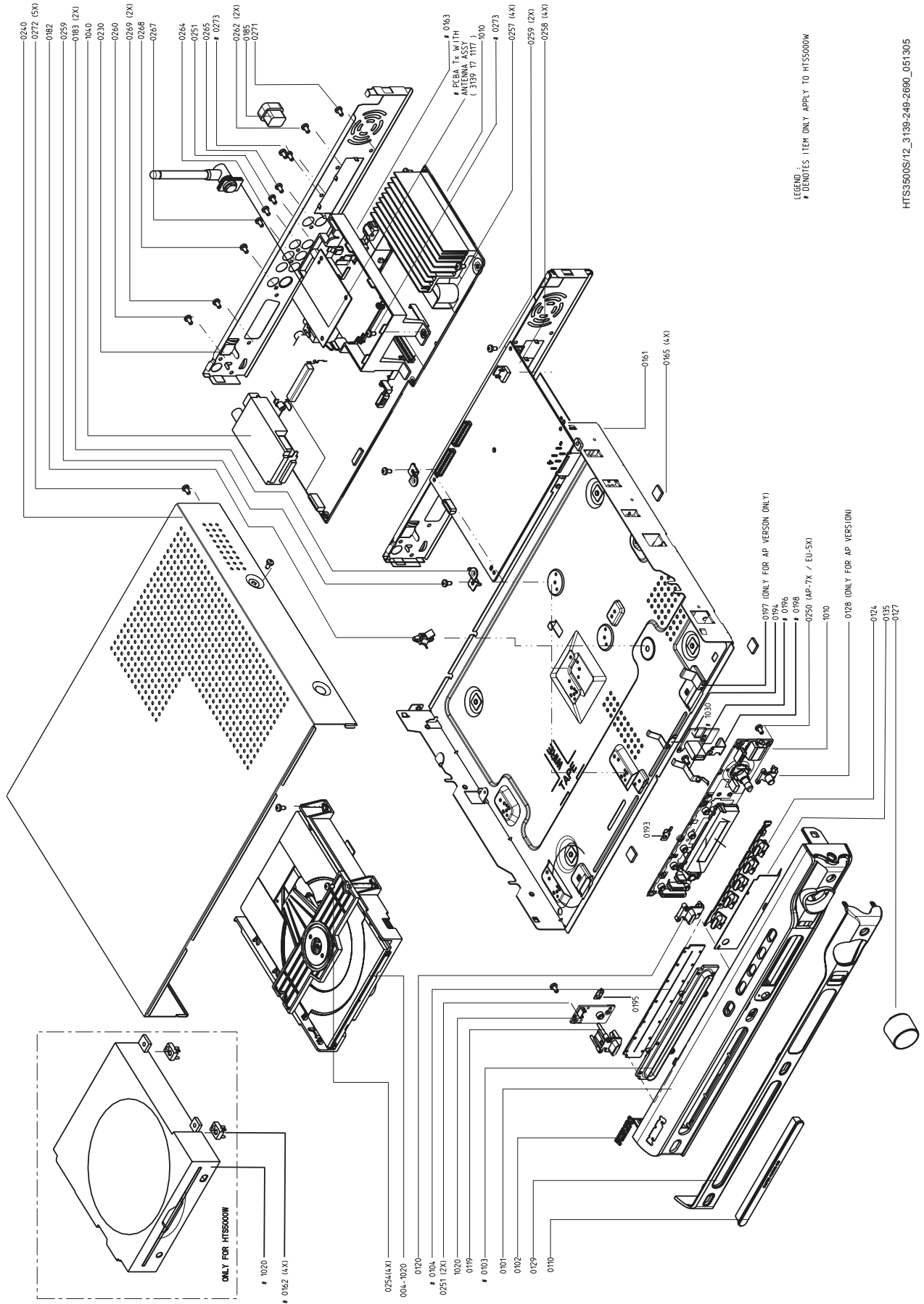

Figure 9-1

**MISCELLANEOUS HTS3300 (05/12/51)**

0110	3139 254 01521	COVER CD TRAY CHROME
0119	3139 244 06041	BUTTON POWER/STANDBY PNT PRT
0120	3139 244 06031	BUTTON OPEN/CLOSE PNT PRT
0124	3139 244 06021	BUTTON SET SOURCE/CTRL PNT PRT
0127	3139 254 01511	KNOB VOL CHROME
0165	3139 243 10081	CUSHION FOOT
0182	3139 254 01571	SPACER PCB H11.4 KGLS-4S
0183	3139 241 21261	BRACKET MONO DVD760
0325	3139 119 02771	BOX SPK ASSY SW-3300HTS/12
0326	3139 119 02761	BOX SPK ASSY CS-3300HTS/12
0331	2422 076 00546	ANT FM WIRE 0M94 24AWG BK B
0332	2422 549 45386	ANT AM LOOP LAN-011 B
0333	3139 258 70111	REMOTE CONTROL HTS3500S EU
0336	2422 070 98236 $\Delta$	MAINSCORD UK 5A 1M8 VH BK B
0342	2422 076 00468 $\Delta$	CBLE SCART 1M1 SCART 21P BK B
0332	2422 549 45813	ANT AM LOOP 039S20014 B
1010	3139 118 58362	PCBA MONO HTS2000D EU
1020	3139 247 11121	LOADER ASSY ST KHM RX
1030	3139 117 11101 $\Delta$	PCBA PSU04-01-200W MITSUMI EU
1040	2422 542 00014	TUN A+F ENG078VVQF EUR B
1050	3139 118 58622	PCBA FRONT HTS2000D EU
8001	3139 111 03781	FFC FOIL 10P/120/10P AD FOLD

**BOX SPK ASSY SW-3300HTS/12**

9965 000 29183	HTS3300 SUBWOOFER
9965 000 28375	RUBBER FOOT
9965 000 28376	CABLE A'SSY 5.3M PURPLE SMK

**BOX SPK ASSY CS-3300HTS/12**

9965 000 29184	SPEAKER BOX FRONT-L
9965 000 29185	SPEAKER BOX FRONT-R
9965 000 29186	SPEAKER BOX REAR-L
9965 000 29187	SPEAKER BOX REAR-R
9965 000 28363	CABLE A'SSY 5.2M WHITE SMK
9965 000 28364	CABLE A'SSY 5.2M RED SMK
9965 000 28365	CABLE A'SSY 5.2M BLUE SMK
9965 000 28366	CABLE A'SSY 5.2M GREY SMK
9965 000 28370	RUBBER FOOT 40LX6WX2.5T
9965 000 29189	SPEAKER BOX CENTER
9965 000 28371	RUBBER FOOT 40.5LX6.0WX1.5T
9965 000 28367	CABLE A'SSY 5.2M GREEN SMK S

**MONO BOARD HTS3300 (05/12/51)****MISCELLANEOUS**

1101	2422 025 17529	CON BM H 24P F 0.50 FFC 0.3 R
1401	2422 025 18516	SOC PUSH H 6P M PUBUGY Y
1402	2422 025 18517	SOC PUSH H 6P M WHGNRD Y
1505	2422 025 14519	CON V 10P F 1.25 FFC 0.3 B
1506	2422 026 05383	SOC CINCH H 2P F 2L1 WHRD Y
1800	2422 025 18315	SOC EURO H 21P F BK L-GRND Y

**CAPACITORS**

2314	2238 600 15614	CER2 0805 X7R 100V 220P PM10 R
2400	2020 021 91431	ELCAP YXA 100V S 22U PM20 A
2408	2238 600 15614	CER2 0805 X7R 100V 220P PM10 R
2411	2238 600 15614	CER2 0805 X7R 100V 220P PM10 R
2412	2238 600 15614	CER2 0805 X7R 100V 220P PM10 R
2416	2238 600 15614	CER2 0805 X7R 100V 220P PM10 R
2420	2238 600 15614	CER2 0805 X7R 100V 220P PM10 R
2427	2020 021 91431	ELCAP YXA 100V S 22U PM20 A
2435	2238 600 15614	CER2 0805 X7R 100V 220P PM10 R
2438	2238 600 15614	CER2 0805 X7R 100V 220P PM10 R
2439	2238 600 15614	CER2 0805 X7R 100V 220P PM10 R
2440	2020 552 96302	CER2 0805 Y5V 50V 220N P8020 R
2443	2238 600 15614	CER2 0805 X7R 100V 220P PM10 R
2447	2238 600 15614	CER2 0805 X7R 100V 220P PM10 R
2454	2020 021 91431	ELCAP YXA 100V S 22U PM20 A
2465	2238 600 15614	CER2 0805 X7R 100V 220P PM10 R
2466	2238 600 15614	CER2 0805 X7R 100V 220P PM10 R
2470	2238 600 15614	CER2 0805 X7R 100V 220P PM10 R
2474	2238 600 15614	CER2 0805 X7R 100V 220P PM10 R

**RESISTORS**

3210	3198 031 11090	RST NETW 1206 4X 10R PM5 COL R
3211	3198 031 11090	RST NETW 1206 4X 10R PM5 COL R
3212	3198 031 11090	RST NETW 1206 4X 10R PM5 COL R
3213	3198 031 11090	RST NETW 1206 4X 10R PM5 COL R
3214	3198 031 11090	RST NETW 1206 4X 10R PM5 COL R
3508	2322 205 33478 $\Delta$	RST FUSE NFR25 A 4R7 PM5 A

**COILS & FILTERS**

5101	3198 018 90040	FXDIND 0603 100MHZ 600R COL R
5104	2422 549 45618	IND FXD 0603 EMI 100MHZ 60R R
5105	2422 549 45618	IND FXD 0603 EMI 100MHZ 60R R
5106	3198 018 90080	FXDIND 0805 100MHZ 600R COL R
5107	3198 018 90080	FXDIND 0805 100MHZ 600R COL R
5113	3198 018 90040	FXDIND 0603 100MHZ 600R COL R
5114	3198 018 90040	FXDIND 0603 100MHZ 600R COL R
5115	3198 018 90040	FXDIND 0603 100MHZ 600R COL R
5116	3198 018 90040	FXDIND 0603 100MHZ 600R COL R
5117	3198 018 90040	FXDIND 0603 100MHZ 600R COL R
5118	3198 018 90040	FXDIND 0603 100MHZ 600R COL R
5119	3198 018 90080	FXDIND 0805 100MHZ 600R COL R
5120	2422 549 45618	IND FXD 0603 EMI 100MHZ 60R R
5122	3198 018 90080	FXDIND 0805 100MHZ 600R COL R
5123	3198 018 90040	FXDIND 0603 100MHZ 600R COL R
5124	3198 018 31090	FXDIND SM 0805 10U PM10 COL R
5125	3198 018 31090	FXDIND SM 0805 10U PM10 COL R
5126	3198 018 90040	FXDIND 0603 100MHZ 600R COL R
5200	3198 018 90040	FXDIND 0603 100MHZ 600R COL R
5300	3198 018 90020	FXDIND BEAD 100MHZ 80R COL A
5301	3198 018 90020	FXDIND BEAD 100MHZ 80R COL A
5400	2422 536 00822	IND FXD 16RHBP S 22U P10M20 B
5401	2422 536 00822	IND FXD 16RHBP S 22U P10M20 B
5402	2422 536 00822	IND FXD 16RHBP S 22U P10M20 B
5403	2422 536 00822	IND FXD 16RHBP S 22U P10M20 B
5404	2422 536 00822	IND FXD 16RHBP S 22U P10M20 B
5405	2422 536 00822	IND FXD 16RHBP S 22U P10M20 B
5604	3198 018 90040	FXDIND 0603 100MHZ 600R COL R



**DIODES**

6100	3198 010 10630	DIO SIG SM BAS316	(COL) R
6300	3198 020 55680	DIO REG SM BZX384-C5V6	COL R
6301	3198 010 10630	DIO SIG SM BAS316	(COL) R
6302	3198 010 10630	DIO SIG SM BAS316	(COL) R
6303	3198 010 10630	DIO SIG SM BAS316	(COL) R
6305	3198 010 10630	DIO SIG SM BAS316	(COL) R
6306	3198 010 10630	DIO SIG SM BAS316	(COL) R
6500	3198 010 10630	DIO SIG SM BAS316	(COL) R
6501	9322 150 08685	DIO REG SM BZX384-C9V1(VISH) R	
6716	3198 010 10630	DIO SIG SM BAS316	(COL) R
6717	3198 010 10630	DIO SIG SM BAS316	(COL) R
6718	3198 010 10630	DIO SIG SM BAS316	(COL) R
6719	3198 010 10630	DIO SIG SM BAS316	(COL) R
6720	3198 010 10630	DIO SIG SM BAS316	(COL) R
6721	3198 010 10630	DIO SIG SM BAS316	(COL) R
6722	3198 010 10630	DIO SIG SM BAS316	(COL) R
6723	3198 010 10630	DIO SIG SM BAS316	(COL) R
6724	3198 010 10630	DIO SIG SM BAS316	(COL) R
6725	3198 010 10630	DIO SIG SM BAS316	(COL) R
6726	3198 010 10630	DIO SIG SM BAS316	(COL) R
6727	3198 010 10630	DIO SIG SM BAS316	(COL) R
6728	3198 010 10630	DIO SIG SM BAS316	(COL) R

**TRANSISTORS & INTREGATED CIRCUITS**

7102	9322 134 45668	IC SM LD1117DT33	(ST00) R
7104	9322 133 00685	TRA POW SM 2SB1132	(ROHM) R
7105	9322 133 00685	TRA POW SM 2SB1132	(ROHM) R
7106	9340 547 13215	FET POW SM BSH103	(PHSE) R
7107	9340 547 13215	FET POW SM BSH103	(PHSE) R
7108	3198 010 44340	TRA SIG SM BC817-25W	(COL) R
7109	9322 216 94671	IC SM MT1389FE/C-L	(MEDI) Y
7110	9322 201 94668	IC SM MM1646XH	(MITM) R
7112	3198 010 42030	TRA SIG SM BC847B	(COL) R
7201	9322 166 67668	IC SM MT48LC4M16A2TG-7EG(MRN)R	
7203	9322 194 74668	IC SM M29W160ET70N6	(ST00) R
7300	3198 010 42030	TRA SIG SM BC847B	(COL) R
7301	9333 726 60653	IC SM HEF4013BT	(PHSE) R
7302	9337 140 00653	IC SM 74HCU04D	(PHSE) R
7305	3198 010 42030	TRA SIG SM BC847B	(COL) R
7306	3198 010 42150	TRA SIG SM BC857B	(COL) R
7307	3198 010 42030	TRA SIG SM BC847B	(COL) R
7308	3198 010 42030	TRA SIG SM BC847B	(COL) R
7309	3198 010 42030	TRA SIG SM BC847B	(COL) R
7310	3198 010 42150	TRA SIG SM BC857B	(COL) R
7400	9352 753 45518	IC SM TDA8922BTH/N2	(PHSE) R
7401	9352 753 45518	IC SM TDA8922BTH/N2	(PHSE) R
7402	9352 753 45518	IC SM TDA8922BTH/N2	(PHSE) R
7502	3198 020 40030	TRA SIG BC547B	(COL) A
7503	9333 729 50653	IC SM HEF4052BT	(PHSE) R
7504	9340 425 20115	TRA SIG SM BC847BS	(PHSE) R
7613	9322 020 18668	IC SM LM833DG	(ONSE) R
7615	9322 215 93668	IC SM CS42406-CQZ	(CILO) R
7616	9322 020 18668	IC SM LM833DG	(ONSE) R
7619	9322 043 00668	IC SM MC78L05ACDG	(ONSE) R
7621	9322 020 18668	IC SM LM833DG	(ONSE) R
7720	3198 010 42030	TRA SIG SM BC847B	(COL) R
7721	9340 425 10115	TRA SIG SM BC857BS	(PHSE) R
7723	9340 425 30115	TRA SIG SM BC847BPN	(PHSE) R
7724	9340 425 30115	TRA SIG SM BC847BPN	(PHSE) R
7725	3198 010 42150	TRA SIG SM BC857B	(COL) R
7804	9340 425 30115	TRA SIG SM BC847BPN	(PHSE) R
7805	9340 425 20115	TRA SIG SM BC847BS	(PHSE) R

**TRANSISTORS & INTREGATED CIRCUITS**

7901	9322 144 97668	IC SM LD1117DT	(ST00) R
7201	9322 205 53668	IC SM A2V64S40DTP-7	(POSE) R *
7201	9322 209 02668	IC SM IS42S16400B-7T	(ISSI) R *

**FRONT BOARD HTS3300 (05/12/51)****MISCELLANEOUS**

1701	3139 111 04131	FTD HUV-08SS57T	(LX-3900SA)
1710	2422 128 02742	SWI TACT H=4.3 160G	SKQNAB A
1711	2422 128 02742	SWI TACT H=4.3 160G	SKQNAB A
1712	2422 128 02742	SWI TACT H=4.3 160G	SKQNAB A
1713	2422 128 02742	SWI TACT H=4.3 160G	SKQNAB A
1714	2422 128 02742	SWI TACT H=4.3 160G	SKQNAB A
1716	2422 128 02742	SWI TACT H=4.3 160G	SKQNAB A

**DIODES**

6700	9322 179 76676	LED VS LTL-816EELC	(LITO) A
6701	934054854115	DIO REG SM PDZ6.2B	(PHSE) R
6704	319801010630	DIO SIG SM BAS316	(COL) R
6705	319801010630	DIO SIG SM BAS316	(COL) R
6706	319801010630	DIO SIG SM BAS316	(COL) R
6707	319801010630	DIO SIG SM BAS316	(COL) R
6708	319801010630	DIO SIG SM BAS316	(COL) R
6709	319801010630	DIO SIG SM BAS316	(COL) R
6710	319801010630	DIO SIG SM BAS316	(COL) R
6711	319801010630	DIO SIG SM BAS316	(COL) R
6712	319801010630	DIO SIG SM BAS316	(COL) R
6713	319801010630	DIO SIG SM BAS316	(COL) R
6714	319801010630	DIO SIG SM BAS316	(COL) R
6715	319801010630	DIO SIG SM BAS316	(COL) R
6716	319801010630	DIO SIG SM BAS316	(COL) R
6717	319801010630	DIO SIG SM BAS316	(COL) R
6718	319801010630	DIO SIG SM BAS316	(COL) R
6719	319801010630	DIO SIG SM BAS316	(COL) R
6720	319801010630	DIO SIG SM BAS316	(COL) R

**TRANSISTORS & INTREGATED CIRCUITS**

7701	9322 185 97667	IR RECEIVER TSOP4836ZC1(VISH)L	
7704	3198 010 42030	TRA SIG SM BC847B	(COL) R
7705	3198 010 43230	TRA SIG SM BC817-25	(COL) R
7706	3198 010 42150	TRA SIG SM BC857B	(COL) R
7707	3198 010 42030	TRA SIG SM BC847B	(COL) R
7708	9322 217 04671	IC SM V63111LF	(VAIT) Y
1901	2422 128 02742	SWI TACT H=4.3 160G	SKQNAB A

**MISCELLANEOUS HTS3300 (55/98/93)**

0119	3139 244 06041	BUTTON POWER/STANDBY PNT PRT
0120	3139 244 06031	BUTTON OPEN/CLOSE PNT PRT
0124	3139 244 06021	BUTTON SET SOURCE/CTRL PNT PRT
0127	3139 254 01511	KNOB VOL CHROME
0128	3139 244 05991	BUTTON MIC LEVEL PNT
0165	3139 243 10081	CUSHION FOOT
0182	3139 254 01571	SPACER PCB H11.4 KGLS-4S
0183	3139 241 21261	BRACKET MONO DVD760
0325	3139 119 02771	BOX SPK ASSY SW-3300HTS/12
0326	3139 119 02761	BOX SPK ASSY CS-3300HTS/12
0331	2422 076 00546	ANT FM WIRE 0M94 24AWG BK B
0332	2422 549 45386	ANT AM LOOP LAN-011 B
0333	3139 258 70101	REMOTE CONTROL HTS3500S AP
0336	2422 070 98231	△ MAINSCORD IEC 2A5 1M8 VH BK B
0338	3103 308 92611	CABLE AUDIO 2X2 RCA MALE 1.5M
0340	2422 076 00208	Cble CINCH/1M7/CINCH NI YE
0332	2422 549 45813	ANT AM LOOP 039S20014 B
1010	3139 118 58352	PCBA MONO HTS2000D ROW
1020	3139 247 11121	LOADER ASSY ST KHM RX
1030	3139 117 11121	△ PCBA PSU 04-05 200W DELTA AP
1040	2422 542 00015	TUN A+F ENG068VVQF USA B
1050	3139 118 58612	PCBA FRONT HTS2000D ROW
8001	3139 111 03781	FFC FOIL 10P/120/10P AD FOLD

**BOX SPK ASSY SW-3300HTS/12**

9965 000 29183	HTS3300 SUBWOOFER
9965 000 28375	RUBBER FOOT
9965 000 28376	CABLE A'SSY 5.3M PURPLE SMK

**BOX SPK ASSY CS-3300HTS/12**

9965 000 29184	SPEAKER BOX FRONT-L
9965 000 29185	SPEAKER BOX FRONT-R
9965 000 29186	SPEAKER BOX REAR-L
9965 000 29187	SPEAKER BOX REAR-R
9965 000 28363	CABLE A'SSY 5.2M WHITE SMK
9965 000 28364	CABLE A'SSY 5.2M RED SMK
9965 000 28365	CABLE A'SSY 5.2M BLUE SMK
9965 000 28366	CABLE A'SSY 5.2M GREY SMK
9965 000 28370	RUBBER FOOT 40LX6WX2.5T
9965 000 29189	SPEAKER BOX CENTER
9965 000 28371	RUBBER FOOT 40.5LX6.0WX1.5T
9965 000 28367	CABLE A'SSY 5.2M GREEN SMK S

**MONO BOARD HTS3300 (05/12/51)****MISCELLANEOUS**

1101	2422 025 17529	CON BM H 24P F 0.50 FFC 0.3 R
1301	2422 540 98568	RES CER 700KHZ CSBLA* B
1401	2422 025 18516	SOC PUSH H 6P M PUBUGY Y
1402	2422 025 18517	SOC PUSH H 6P M WHGNRD Y
1502	2422 026 05462	SOC CINCH H 4P F 2L2 WHRD Y
1505	2422 025 14519	CON V 10P F 1.25 FFC 0.3 B
1807	2422 026 05708	SOC CINCH H 4P F 2L2 Y

**CAPACITORS**

2400	2020 021 91431	ELCAP YXA 100V S 22U PM20 A
2411	2238 600 15614	CER2 0805 X7R 100V 220P PM10 R
2412	2238 600 15614	CER2 0805 X7R 100V 220P PM10 R
2416	2238 600 15614	CER2 0805 X7R 100V 220P PM10 R
2420	2238 600 15614	CER2 0805 X7R 100V 220P PM10 R
2427	2020 021 91431	ELCAP YXA 100V S 22U PM20 A
2435	2238 600 15614	CER2 0805 X7R 100V 220P PM10 R
2438	2238 600 15614	CER2 0805 X7R 100V 220P PM10 R
2439	2238 600 15614	CER2 0805 X7R 100V 220P PM10 R
2443	2238 600 15614	CER2 0805 X7R 100V 220P PM10 R
2447	2238 600 15614	CER2 0805 X7R 100V 220P PM10 R
2454	2020 021 91431	ELCAP YXA 100V S 22U PM20 A
2465	2238 600 15614	CER2 0805 X7R 100V 220P PM10 R
2466	2238 600 15614	CER2 0805 X7R 100V 220P PM10 R
2470	2238 600 15614	CER2 0805 X7R 100V 220P PM10 R
2474	2238 600 15614	CER2 0805 X7R 100V 220P PM10 R

**RESISTORS**

3210	3198 031 11090	RST NETW 1206 4X 10R PM5 COL R
3211	3198 031 11090	RST NETW 1206 4X 10R PM5 COL R
3212	3198 031 11090	RST NETW 1206 4X 10R PM5 COL R
3213	3198 031 11090	RST NETW 1206 4X 10R PM5 COL R
3214	3198 031 11090	RST NETW 1206 4X 10R PM5 COL R

**COILS & FILTERS**

5101	3198 018 90040	FXDIND 0603 100MHZ 600R COL R
5104	2422 549 45618	IND FXD 0603 EMI 100MHZ 60R R
5105	2422 549 45618	IND FXD 0603 EMI 100MHZ 60R R
5106	3198 018 90080	FXDIND 0805 100MHZ 600R COL R
5107	3198 018 90080	FXDIND 0805 100MHZ 600R COL R
5108	2422 543 01393	RES XTL SM 27MHZ 10P CX8045 R
5113	3198 018 90040	FXDIND 0603 100MHZ 600R COL R
5114	3198 018 90040	FXDIND 0603 100MHZ 600R COL R
5115	3198 018 90040	FXDIND 0603 100MHZ 600R COL R
5116	3198 018 90040	FXDIND 0603 100MHZ 600R COL R
5117	3198 018 90040	FXDIND 0603 100MHZ 600R COL R
5118	3198 018 90040	FXDIND 0603 100MHZ 600R COL R
5119	3198 018 90080	FXDIND 0805 100MHZ 600R COL R
5120	2422 549 45618	IND FXD 0603 EMI 100MHZ 60R R
5122	3198 018 90080	FXDIND 0805 100MHZ 600R COL R
5123	3198 018 90040	FXDIND 0603 100MHZ 600R COL R
5124	3198 018 31090	FXDIND SM 0805 10U PM10 COL R
5125	3198 018 31090	FXDIND SM 0805 10U PM10 COL R
5126	3198 018 90040	FXDIND 0603 100MHZ 600R COL R
5200	3198 018 90040	FXDIND 0603 100MHZ 600R COL R
5300	3198 018 90020	FXDIND BEAD 100MHZ 80R COL A
5301	3198 018 90020	FXDIND BEAD 100MHZ 80R COL A
5400	2422 536 00822	IND FXD 16RHBP S 22U P10M20 B
5401	2422 536 00822	IND FXD 16RHBP S 22U P10M20 B
5402	2422 536 00822	IND FXD 16RHBP S 22U P10M20 B
5403	2422 536 00822	IND FXD 16RHBP S 22U P10M20 B
5404	2422 536 00822	IND FXD 16RHBP S 22U P10M20 B
5405	2422 536 00822	IND FXD 16RHBP S 22U P10M20 B
5604	3198 018 90040	FXDIND 0603 100MHZ 600R COL R

**DIODES**

6100	3198 010 10630	DIO SIG SM BAS316 (COL) R
6300	3198 020 55680	DIO REG SM BZX384-C5V6 COL R
6301	3198 010 10630	DIO SIG SM BAS316 (COL) R
6302	3198 010 10630	DIO SIG SM BAS316 (COL) R
6303	3198 010 10630	DIO SIG SM BAS316 (COL) R
6305	3198 010 10630	DIO SIG SM BAS316 (COL) R
6306	3198 010 10630	DIO SIG SM BAS316 (COL) R
6500	3198 010 10630	DIO SIG SM BAS316 (COL) R
6501	9322 150 08685	DIO REG SM BZX384-C9V1(VISH) R
6716	3198 010 10630	DIO SIG SM BAS316 (COL) R
6717	3198 010 10630	DIO SIG SM BAS316 (COL) R
6718	3198 010 10630	DIO SIG SM BAS316 (COL) R
6719	3198 010 10630	DIO SIG SM BAS316 (COL) R
6720	3198 010 10630	DIO SIG SM BAS316 (COL) R
6721	3198 010 10630	DIO SIG SM BAS316 (COL) R
6722	3198 010 10630	DIO SIG SM BAS316 (COL) R
6723	3198 010 10630	DIO SIG SM BAS316 (COL) R
6725	3198 010 10630	DIO SIG SM BAS316 (COL) R
6727	3198 010 10630	DIO SIG SM BAS316 (COL) R

**TRANSISTORS & INTREGATED CIRCUITS**

7102	9322 134 45668	IC SM LD1117DT33 (ST00) R
7104	9322 133 00685	TRA POW SM 2SB1132 (ROHM) R
7105	9322 133 00685	TRA POW SM 2SB1132 (ROHM) R
7106	9340 547 13215	FET POW SM BSH103 (PHSE) R
7107	9340 547 13215	FET POW SM BSH103 (PHSE) R
7108	3198 010 44340	TRA SIG SM BC817-25W (COL) R
7109	9322 216 94671	IC SM MT1389FE/C-L (MEDI) Y
7110	9322 201 94668	IC SM MM1646XH (MITM) R
7112	3198 010 42030	TRA SIG SM BC847B (COL) R
7201	9322 166 67668	IC SM MT48LC4M16A2TG-7EG(MRN)R
7203	9322 194 74668	IC SM M29W160ET70N6 (ST00) R
7300	3198 010 42030	TRA SIG SM BC847B (COL) R
7301	9333 726 60653	IC SM HEF4013BT (PHSE) R
7302	9337 140 00653	IC SM 74HCU04D (PHSE) R
7305	3198 010 42030	TRA SIG SM BC847B (COL) R
7306	3198 010 42150	TRA SIG SM BC857B (COL) R
7307	3198 010 42030	TRA SIG SM BC847B (COL) R
7308	3198 010 42030	TRA SIG SM BC847B (COL) R
7309	3198 010 42030	TRA SIG SM BC847B (COL) R
7310	3198 010 42150	TRA SIG SM BC857B (COL) R
7400	9352 753 45518	IC SM TDA8922BTH/N2 (PHSE) R
7401	9352 753 45518	IC SM TDA8922BTH/N2 (PHSE) R
7402	9352 753 45518	IC SM TDA8922BTH/N2 (PHSE) R
7500	9322 068 82668	IC SM LM833D (ST00) R
7502	3198 020 40030	TRA SIG BC547B (COL) A
7503	9333 729 50653	IC SM HEF4052BT (PHSE) R
7613	9322 020 18668	IC SM LM833DG (ONSE) R
7615	9322 215 93668	IC SM CS42406-CQZ (CILO) R
7616	9322 020 18668	IC SM LM833DG (ONSE) R
7619	9322 043 00668	IC SM MC78L05ACDG (ONSE) R
7621	9322 020 18668	IC SM LM833DG (ONSE) R
7720	3198 010 42030	TRA SIG SM BC847B (COL) R
7721	9340 425 10115	TRA SIG SM BC857BS (PHSE) R
7723	9340 425 30115	TRA SIG SM BC847BPN (PHSE) R
7724	9340 425 30115	TRA SIG SM BC847BPN (PHSE) R
7901	9322 144 97668	IC SM LD1117DT (ST00) R
7201	9322 205 53668	IC SM A2V64S40DTP-7 (POSE) R
7201	9322 209 02668	IC SM IS42S16400B-7T (ISSI) R

**FRONT BOARD HTS3300 (55/98/93)****MISCELLANEOUS**

1701	3139 111 04131	FTD HUV-08SS57T (LX-3900SA)
1709	2422 026 05691	SOC PHONE H 1P F 3.5 MSJ Y
1710	2422 128 02742	SWI TACT H=4.3 160G SKQNAB A
1711	2422 128 02742	SWI TACT H=4.3 160G SKQNAB A
1712	2422 128 02742	SWI TACT H=4.3 160G SKQNAB A
1713	2422 128 02742	SWI TACT H=4.3 160G SKQNAB A
1714	2422 128 02742	SWI TACT H=4.3 160G SKQNAB A
1715	2422 128 02742	SWI TACT H=4.3 160G SKQNAB A
1716	2422 128 02742	SWI TACT H=4.3 160G SKQNAB A

**COILS & FILTERS**

5700	3198 017 22250	CER2 0805 Y5V 10V 2U2 COL R
------	----------------	-----------------------------

**DIODES**

6700	9322 179 76676	LED VS LTL-816EELC (LITO) A
6701	9340 548 54115	DIO REG SM PDZ6.2B (PHSE) R
6703	3198 010 10630	DIO SIG SM BAS316 (COL) R
6704	3198 010 10630	DIO SIG SM BAS316 (COL) R
6705	3198 010 10630	DIO SIG SM BAS316 (COL) R
6706	3198 010 10630	DIO SIG SM BAS316 (COL) R
6707	3198 010 10630	DIO SIG SM BAS316 (COL) R
6708	3198 010 10630	DIO SIG SM BAS316 (COL) R
6709	3198 010 10630	DIO SIG SM BAS316 (COL) R
6710	3198 010 10630	DIO SIG SM BAS316 (COL) R
6711	3198 010 10630	DIO SIG SM BAS316 (COL) R
6712	3198 010 10630	DIO SIG SM BAS316 (COL) R
6713	3198 010 10630	DIO SIG SM BAS316 (COL) R
6714	3198 010 10630	DIO SIG SM BAS316 (COL) R
6715	3198 010 10630	DIO SIG SM BAS316 (COL) R
6716	3198 010 10630	DIO SIG SM BAS316 (COL) R
6717	3198 010 10630	DIO SIG SM BAS316 (COL) R
6718	3198 010 10630	DIO SIG SM BAS316 (COL) R
6719	3198 010 10630	DIO SIG SM BAS316 (COL) R
6720	3198 010 10630	DIO SIG SM BAS316 (COL) R

**TRANSISTORS & INTREGATED CIRCUITS**

7701	9322 185 97667	IR RECEIVER TSOP4836ZC1(VISH)L
7702	9322 068 82668	IC SM LM833D (ST00) R
7703	3198 010 42030	TRA SIG SM BC847B (COL) R
7704	3198 010 42030	TRA SIG SM BC847B (COL) R
7705	3198 010 43230	TRA SIG SM BC817-25 (COL) R
7706	3198 010 42150	TRA SIG SM BC857B (COL) R
7707	3198 010 42030	TRA SIG SM BC847B (COL) R
7708	9322 217 04671	IC SM V63111LF (VAIT) Y
1901	2422 128 02742	SWI TACT H=4.3 160G SKQNAB A

**11 REVISION LIST**

11.1 Manual 3139 785 31171

1 Replace of schematic diagram (point 4) in page 22 of document.

11.2 Manual 3139 785 31172

1 Revise of spare part list for HTS3300/98/93/55/51/12/05